

HELIPORT PERIMETER LIGHT

Model 1000 LED



INSTALLATION INSTRUCTIONS

AND

TECHNICAL MANUAL

Flight Light Inc. • 2708 47th Ave. • Sacramento, CA 95822-3806 USA
www.heliportlighting.com • (916) 394-2800

PERIMETER LIGHT

Model 1000 LED

TECHNICAL MANUAL

FUNCTION, DESCRIPTION and SPECIFICATION INSTALLATION INSTRUCTION and MAINTENANCE

GENERAL

If you want to go green and save our planet use our new Perimeter Light, Model 1000 LED, which is designed to provide a lighted outline of the heliport landing area without using too much electricity. With its long lasting life lamp you will not have to worry about changing the lamp so often. The LED Lamp will last for many years. The aqua green color of the lamp does not affect flying with night vision goggles.

The Perimeter light, Model 1000 LED is of rugged design and a low overall height. Its omnidirectional heat resistant lens is designed to provide a steeper beam pattern than those commonly used on fixed wing airports to accommodate the steeper landing requirements of helicopters. A stainless steel wire guard protects the lens from damage. The light output is approximately 40 watts and the fixture is powered by 110VAC or it may be ordered with 220VAC.

CONSTRUCTION

The Perimeter Light is heavily constructed and is weather tight. The housing cover are of cast aluminum and are precision machined for close fit and a flat neoprene gasket seals it to be weatherproof. The green glass lens covers the low voltage lamp and it is then protected by a stainless steel wire guard. The cover and all parts are installed with stainless steel screws.

INSTALLATION

For heliport installations regulated by the FAA, the Perimeter Light should be located outside and within 10 foot (3m) of the edge of the TLOF or the outer of the safety net (Elevated Heliport). For ground base heliports, the Perimeter Light may only be used if the TLOF is load bearing. Perimeter lights shall be uniformly spaced at intervals of no more than 25 foot (7.5m) and there shall be a minimum of four lights on each side including a light near each corner. The Perimeter Light should not exceed a height of 2 inches (5cm) otherwise it should be inset.

For heliport installations regulated by ICAO, the Perimeter Light shall be placed along the edge of the TLOF or within a distance of 5 foot (1.5m) of the edge of the TLOF. Perimeter Lights shall be uniformly spaced at intervals of not more than 16 foot (5m, ground base) or 10 foot (3m, elevated heliport) and there shall be a minimum of four lights on each side including a light at each corner. The Perimeter Lights should not exceed a height of 10 inches (25cm) or should be inset when they could endanger helicopter operations.

The Perimeter Light could be installed to the concrete surface or often on adjacent concrete pads depending on the regulatory agencies. Two 1/2" expansion bolts are secured in the concrete, with the threads extending up about 1 1/2". The Perimeter Light housing has two cast in lugs which drop down over those bolts and a flat washer together with the 1/2" nut, screws down to hold the fixture in place.

The fixture is supplied with approximately 15 inches (38 cm) of three conductor, #16-3, SJO type cable, which connects to the circuit and the related junction box. Flexible conduit is often used to house the cable for this connection

ELECTRICAL

The Perimeter Light has a miniature LED lamp that is rated at 24 volts and has a light output of 40 watts. It only consumes 2.2 Watts (LED Lamp) instead of 40 Watts (Regular Lamp) which makes a big saving in electricity. It is connected to a transformer which reduces the incoming voltage from 110Vac to 24volts. The transformer is connected by electrical cable through a 1/2" pipe threaded hole in the side of the fixture, to the junction box and to the circuit. The lamp has a rated life of approximately 50,000 hours. As previously stated, we recommend the use of the Radio Controller to control the use of the circuit and extend the lamp life of all lamp bulbs in the system.

MAINTENANCE

In general, maintenance is related to the replacement of lamps bulbs. The lamp is replaced by removing the lens guard, the lens and the used lamp. The replacement lamp is installed and the lens and the lens guard are reinstalled.

The Perimeter Light is originally finished in orange colored powder coating polyester, the most permanent finish available and can be polished from time to time to remove dirt, which will make it look like new again.

PERIMETER LIGHT CUT AWAY VIEW DRAWING

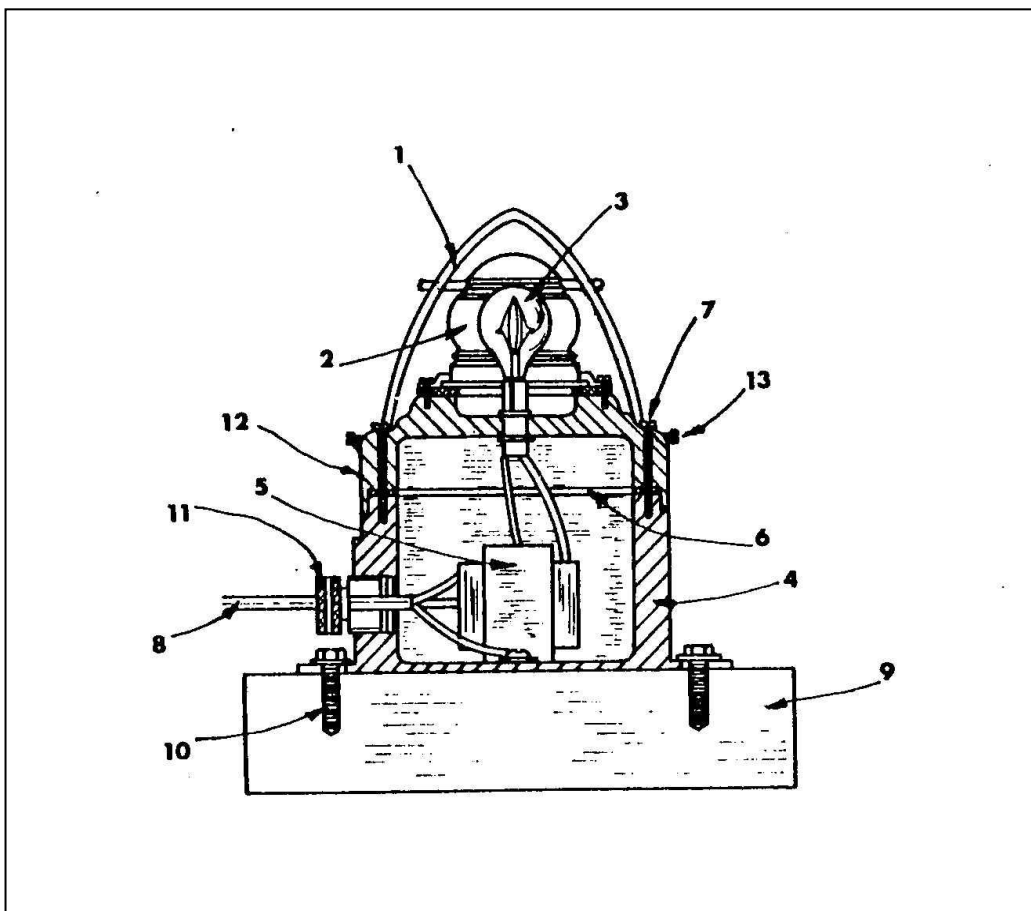

ITEM	DESCRIPTION
1	Lens Wire Guard
2	Lens (Glass) Yellow, Blue, Red, Green
3	LED Lamp Bulb
4	Aluminum Housing
5	Transformer
6	Cover Gasket
7	Cover Screw
8	Power Cable
9	Concrete Pad
10	½" Anchor Screw
11	Cord Grip
12	Aluminum Cover Casting
13	Adjusting Screws

PARTS LIST

Part Description	#Required	Part Number
Aluminum Housing	1	HSG-1000-01-001
Aluminum Cover Casting	1	HSG-1000-02-001
Lens, Glass, Green	1	LGR-1000-02-002G
Lens Guard, Wire	1	LGR-1000-02-003
Lens Retainer Ring	1	RET-1000-02-004
Lens Gasket	1	GSK-1000-02-005
Cover Gasket	1	GSK-1000-01-002
Transformer	1	PWR-1000-01-003
Lamp	1	LED-1000-1G-024
Lamp Socket	1	SKP-1000-02-006

WARRANTY

THE PERIMETER LIGHT, MODEL 1000 IS WARRANTED AGAINST DEFECTS IN WORKMANSHIP AND MATERIALS FOR A PERIOD OF ONE YEAR BUT NOT AGAINST MISUSE OR IMPROPER INSTALLATION OR OTHER.