

Radio Receiver/Decoder FAA L-854

Compliance and Applications

- FAA type: L-854 Radio Receiver/Decoder, Air-to-ground, Type 1, Style A
- ETL Certified to: FAA AC 150/5345-49D

Our L-854 FM radio receiver/decoder is designed to provide pilots direct, unassisted air-to-ground control of airfield lighting systems. This field tunable radio allows pilots to activate airfield lighting with a series of 3, 5, or 7 microphone clicks in a 5 second period. An integrated selectable timer shuts airfield lights off after 1, 15, 30, or 60 minutes of illumination.

Our L-854 receiver is particularly useful for small to mid-sized airfields where continuous nighttime illumination is unnecessary and expensive. The unit is a virtual necessity for remote sites where the volume of air traffic or the availability of qualified on-site control personnel may be limited. Our rugged, solid state design will provide years of service and is the perfect replacement for aging "crystal" based units.

Features

- 100% field tunable within the 118-136MHz airband, in .025MHz increments.
- Relay bank operation is easily selectable from front panel.
- Operate indoors or outdoors, temperature range -67°F to +131°F (-55°C to +55°C).
- Standard long life mechanical relays ensure compatibility with your equipment.
- Our solid state receiver design makes for extremely low power consumption.
- Standard construction features a rugged NEMA 4/12 enclosure. Custom cabinets are available.
- Custom designs are available for OEM integration, solar deployment and mobile operation. Ask our engineers to build your exact model needs.
- Capable of a wide range of operating voltages from 100-240VAC, 50 or 60 Hz. DC version is available.

Installation

- Front panel screw clamp terminals are contractor friendly and make installations a breeze.
- Deployment is as easy as hanging the unit, providing a radio power source, wiring control power inputs and outputs and mounting the antenna.
- No mast or other mounting hardware is provided. L-854 Antenna Cable Kit sold separately.



L-854 Radio Receiver/Decoder
(P/N: 47-RDL854-1A)

L-854 Antenna Cable Kit

- 25' of coax cable
- BNC & UHF connections
- Mounting bracket
- Surge protector
- P/N: 47-L854ACK-25



Ordering Codes

Model	Input Power ¹	Load ²
47-RDL854-1A	AC: 100-240VAC DC: 12VDC	30: 30 AMP (heavy duty) 40: 40 AMP (heavy duty)

¹ 6.6 AMP (std). ² Load option for AC input power only.

Important: If the controller is used for a helipad application, whether AC or DC, the total wattage being controlled must be specified. Please be aware that radio controllers used for voltage applications are not dimmable.

Dimensions: 10" x 12.75" (25.4 cm x 32.385 cm). **Weight:** 28 lb. (12.7 kg)



RDL8541A ELECTRICAL CHARACTERISTICS @ 120VAC 60Hz			
INPUT VOLTAGE	AC CURRENT STANDBY MODE	AC CURRENT ACTIVE MODE	AC CURRENT W/100W HEATER ON
90-264 VAC, 50-60Hz AUTO SENSING	0.088 A	0.1 A	1.4 A

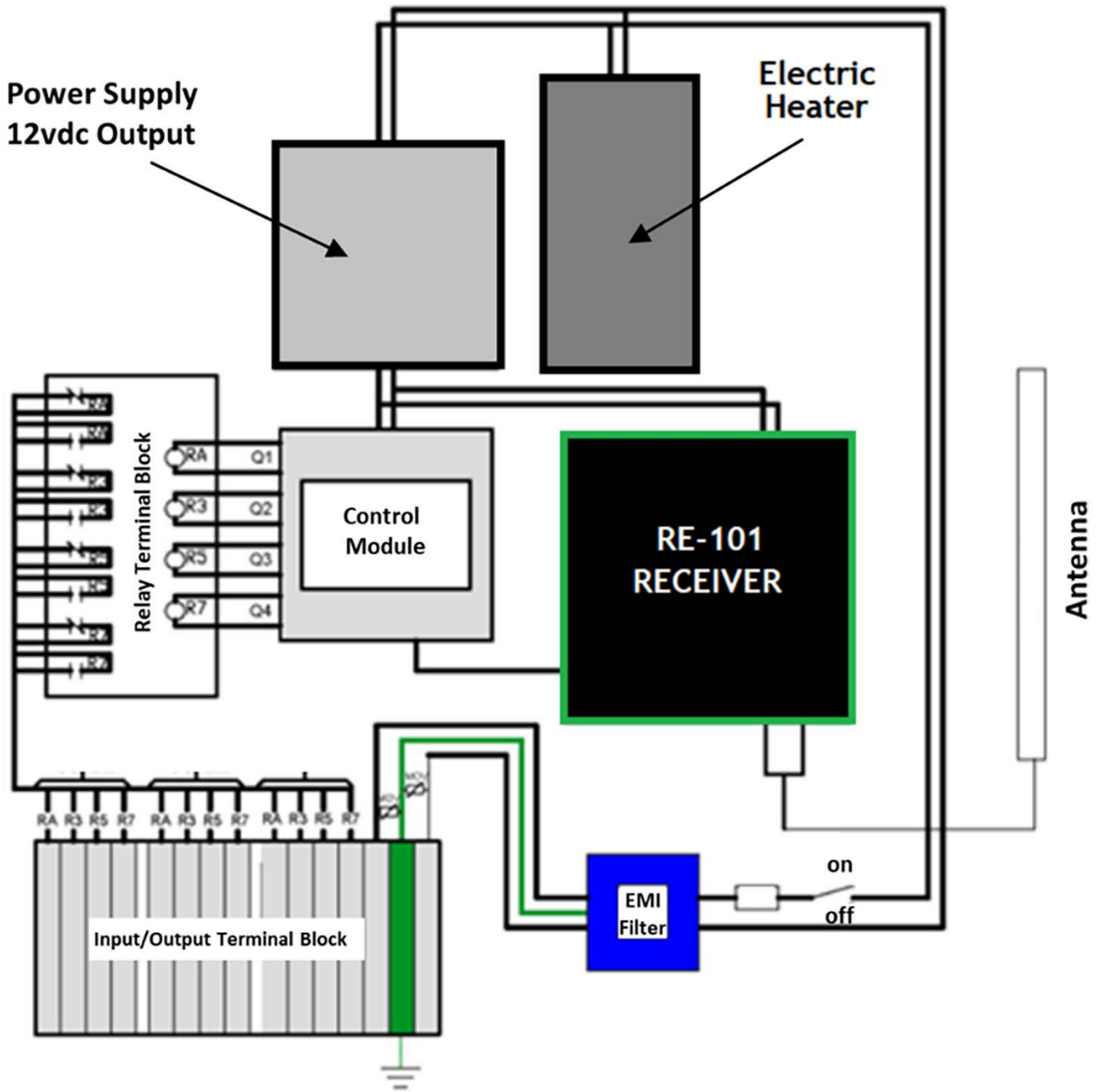

Component Layout