

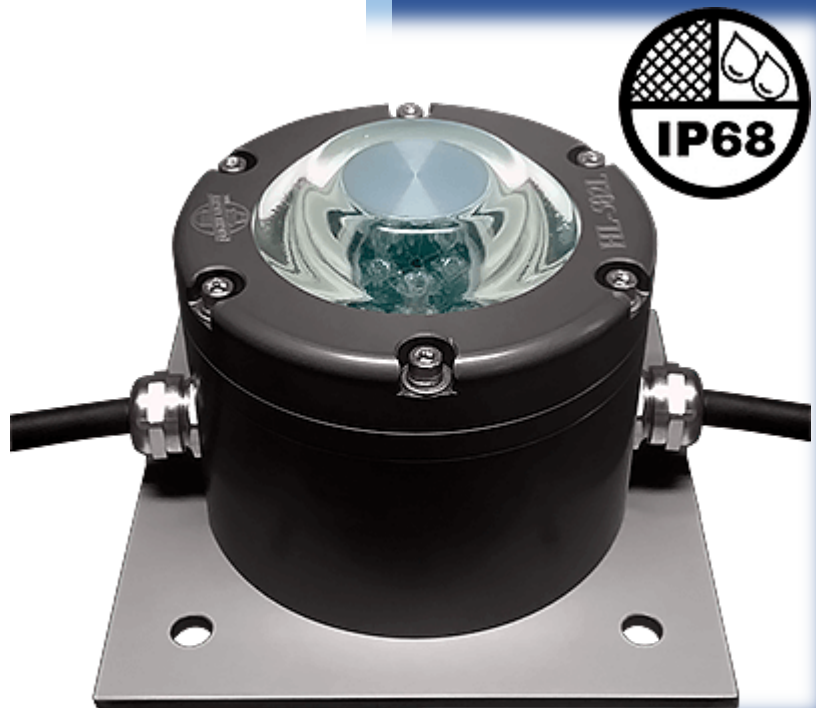

Installation Manual 582



www.flightlight.com

Ph: 1.800.806.3548 916.394.2800

Fax: 916-394-2809

2708 47th Avenue, Sacramento

CA 95822





Your Flight Light 582 light fixtures have been designed to provide you years of service if you follow the recommendations outlined in this guide. Flight Light recommends that any installation of our heliport or helideck fixtures follow NEC (National Electrical Code) 2014 and any other applicable local electrical codes.

Our fixture is compliant with:

- FAA AC 150/5390-2B Heliport Design Guide
- Exceeds FAA Engineering Brief 87 Specifications
- Transport Canada TP14371, AGA 7.16
- IP68 Rating

The **Night Vision Compatibility** feature, allows pilots to see the lights while wearing Night Vision Goggles due to the IR (infrared) LED. The light is compatible with all generation goggles.

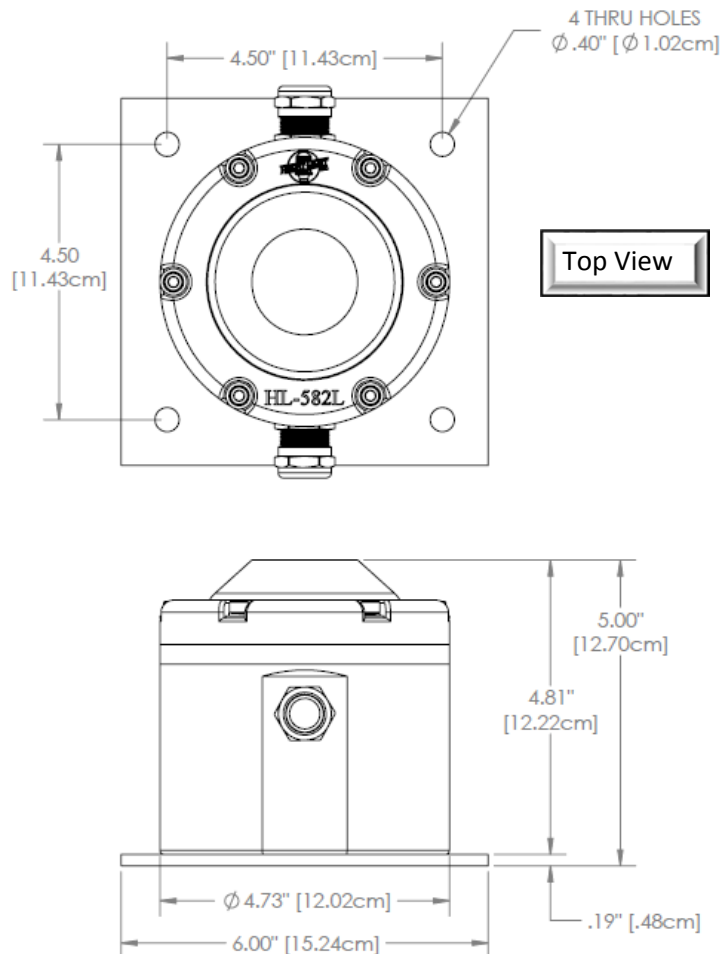

HL-582 Perimeter Light General Arrangement





Table of Contents

1. Introduction	1
1.1 About the manual	1
2. Safety Measures	2
3. Installation Procedures	3
3.1 Unpacking	3
3.2 Electrical Wiring	4
3.2a LED Lights AC and LED Lights AC with IR.....	7
3.2b LED Lights DC and LED Lights DC with IR	8
3.2c LED Lights DC Dimming and LED Lights DC Dimming with IR.....	9
3.3 Installation	10
4. Maintenance	11
5. Replacement Parts	11
6. Limited Warranty	12



1. Introduction

The Flight Light model 582 is an anodized Type III aluminum fixture suitable for a variety of environments. The hard anodization makes it corrosion resistant, increases wear resistance, increases abrasion resistance and flame resistance.

IP68 compliant, water resistant fixture can be submerged in water for several days and still function properly. Impenetrable, factory epoxy potted LED driver and LED board cavity maximizes LED life.

Fully made in the USA, complies with the Buy American Act.

Robust design, user friendly, incorporates the light and the plate in one unit for easy and quick installation in soil, concrete, asphalt, decks or metal platforms. Available in VDC and VAC, the light will ensure proper visual guidance conforming to FAA requirements.

Due to its compact design, can be efficiently used for any temporary application as a portable light.

The installation and maintenance should be done by authorized personnel only.

For questions or guidance during the installation process, please contact our office as engineers and technician are always available to help you.

Phone number: 1-800-806-3458
916-394-2800

OR send an email request to sales@flightlight.com

1.1 About the manual

This manual contains the needed instructions to complete a successful installation. Failure to install the system properly will negatively impact the performance of the system, shorten its life and may void the manufacturer's warranty.

Not all the items that will be needed to complete the installation are included with the light. The installation procedures section will describe any additional products/tools that may be needed.



2. Safety Measures

You must know whether your heliport lighting system is powered by AC or DC before installing the fixture. AC models work on a range of 100 to 240VAC and DC models operate from 10 to 30VDC. The lights are designed to be installed in a parallel circuit, which maintains a constant voltage and brightness for all lights.

Ensure power is off before installing or servicing heliport fixtures!

Follow the local electrical code!

Make sure the equipment is rated and approved for the environment in which you are intending to use it. Do not operate this equipment in humid, flammable, or explosive environments unless it has been rated for safe operation in these environments.

Use only electrical wire of sufficient gauge and insulation to handle the rated current and voltage demand.

Route electrical wiring along a protected path. Make sure they will not be damaged by moving equipment.

Protect components from harsh environment conditions.

Protect equipment with safety devices as specified by applicable safety regulations.

Before starting this equipment, check all safety interlocks, fire –detection systems, and protective devices such as panels and covers. Make sure all devices are fully functional. Do not operate the system if these devices are not working properly.

Never operate equipment with a known malfunction.

Do not attempt to operate or service electrical equipment if standing water is present.

Do not touch exposed electrical connections on equipment while the power is ON!

Wiring and electrical design should be authorized by an electrical contractor.

To provide maximum protection from surges, ensure that the system ground is tested and provides less than 25 ohms to ground resistance.



3. Installation Procedures

3.1 Unpacking

Each light is shipped in its own box, together with the needed hardware for the wiring:

- 5 gel connectors, 3 needed for initial wiring and 2 spare ones
- 2 cord grips
- 4 socket head screws 1.25" long, 4 flat washers and 4 lock washers

Carefully remove the light from its box and inspect for damages. If any damages are found, file a claim with the carrier. Note any exterior damage to the carton that might lead to detection of equipment damage.

Cable is not provided by Flight Light Inc.

The gauge of the wire intended to be used for the connection of the lighting fixtures is to be calculated by the electrical engineer and should be sufficient to handle the rated current and voltage demand.

Cable Minimum Requirements:

- Cable Range O.D. = .24" - .47" (6 - 12 mm)
- Recommended AWG (Varies by application): 16-3/C SOOW 600V 90C
- UL Listed
- Water Resistant



3.2 Electrical Wiring

The light fixture comes with only two of the head screws securing the assembly.

Remove the screws to open the fixture and prepare it for wiring. Save the screws as they will be needed later for closing the fixture.



Picture #1

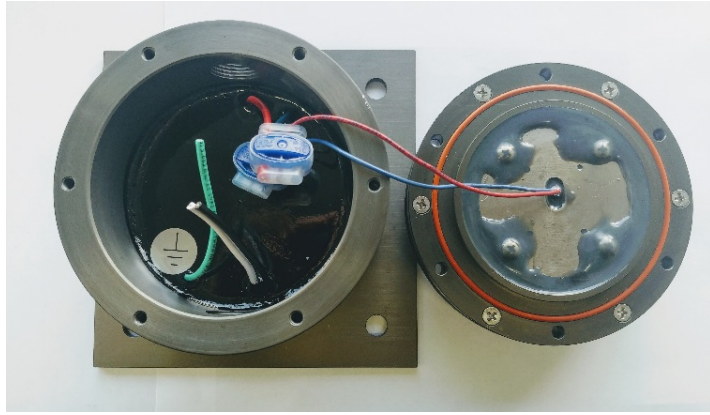

Picture #2

The bottom and top assembly wiring for the LED is done in the factory.

The AC version fixture has a black (Line), white (Neutral) and green (ground) wires coming from the bottom, which will be used to connect/splice to the incoming input wires.

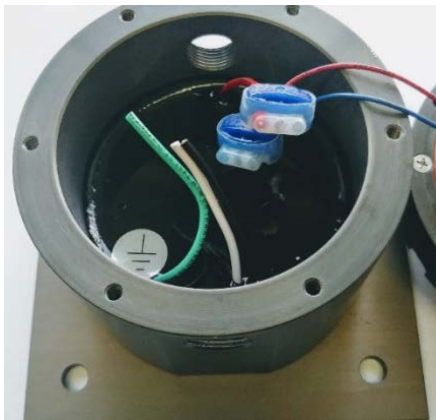

Picture #3



1. Take both incoming cables and remove the external jacket, as shown in picture #4 below.
2. Run the cables through the cord grips.

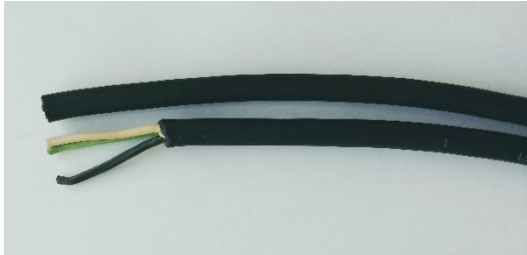

Picture #4



Picture #5

3. Apply loctite over the threads of the cord grips and thread them in the side entries without fully tightening them. Adjust the length of the cables inside the fixture. Make sure the length of the incoming wires matches the length of the wires coming from the bottom of the fixture. Now fully tighten both cord grips using a wrench.



Picture #6



Picture #7

4. **DO NOT STRIP THE WIRES!**
5. Use the three gel connectors sent with the fixture to make the splicing.
6. Plug each black wire in one gel connector, one wire in each position.
7. Plug each white wire in one gel connector, one wire in each position.
8. Plug each green wire in one gel connector, one wire in each position.

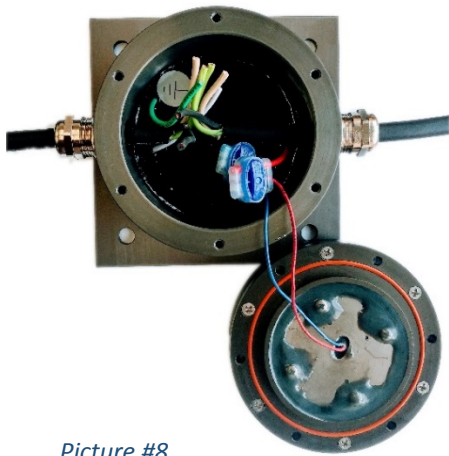

Picture #8

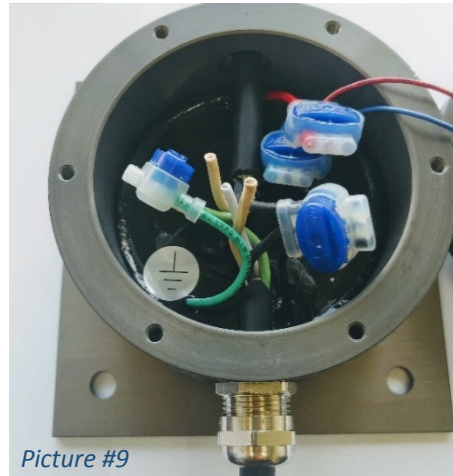

Picture #9

9. Using a wrench squeeze each one of the gel connectors.

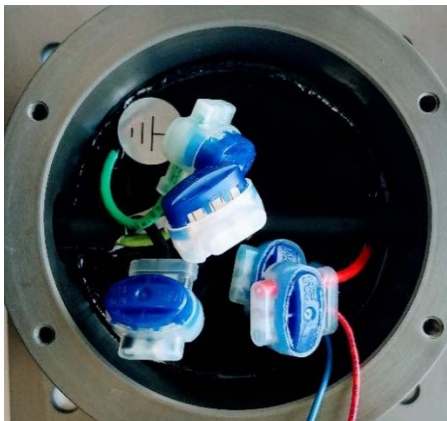

Picture #10

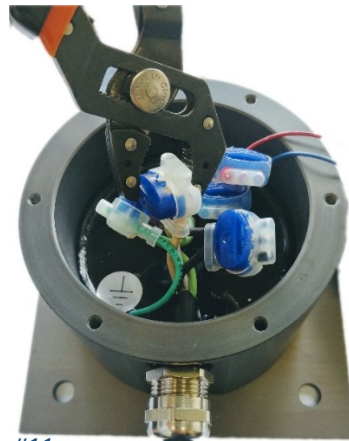

Picture #11

The electrical wiring of the light is recommended to be done in a parallel circuit with the splice done inside the light fixture. Junction boxes are not provided with the light fixtures.

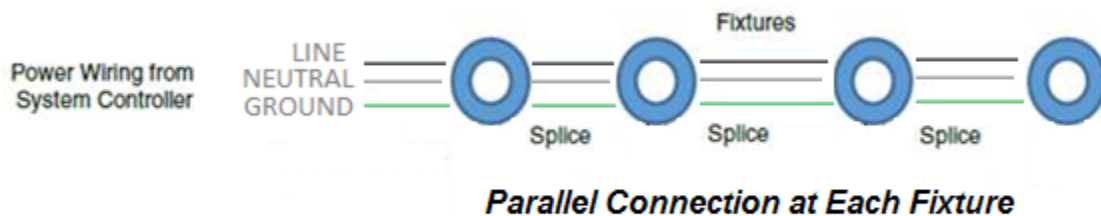
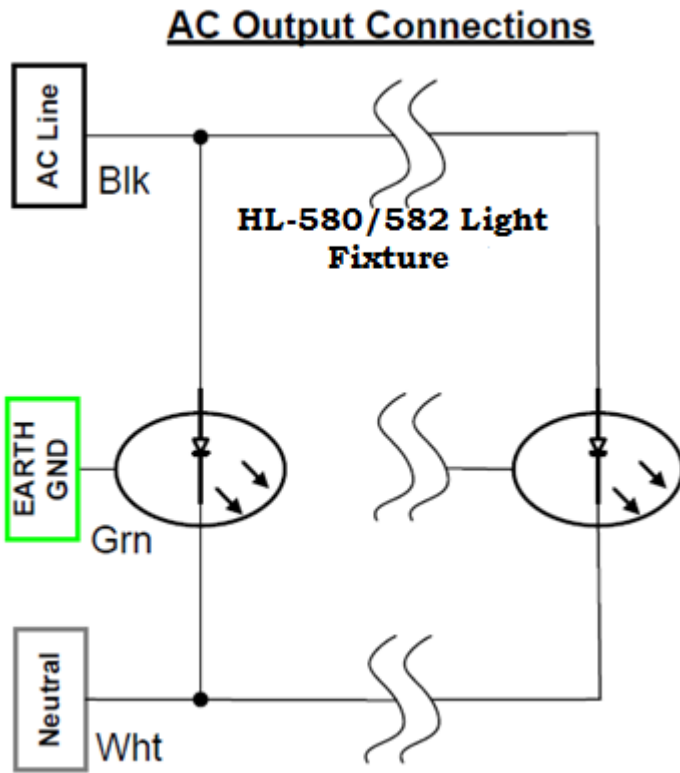
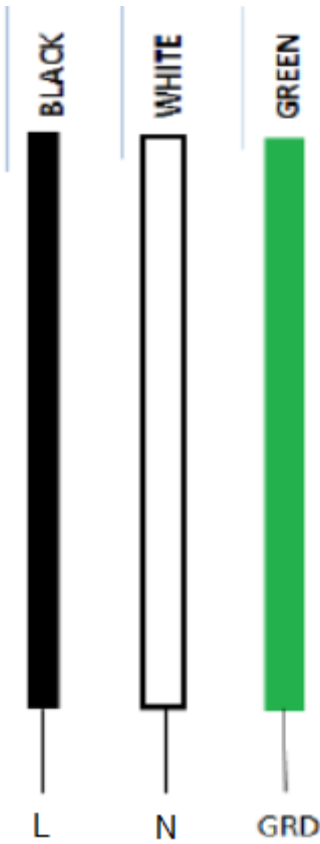

Figure 1



3.2a LED Lights AC and LED Lights AC with IR





3.2b LED Lights DC and LED Lights DC with IR

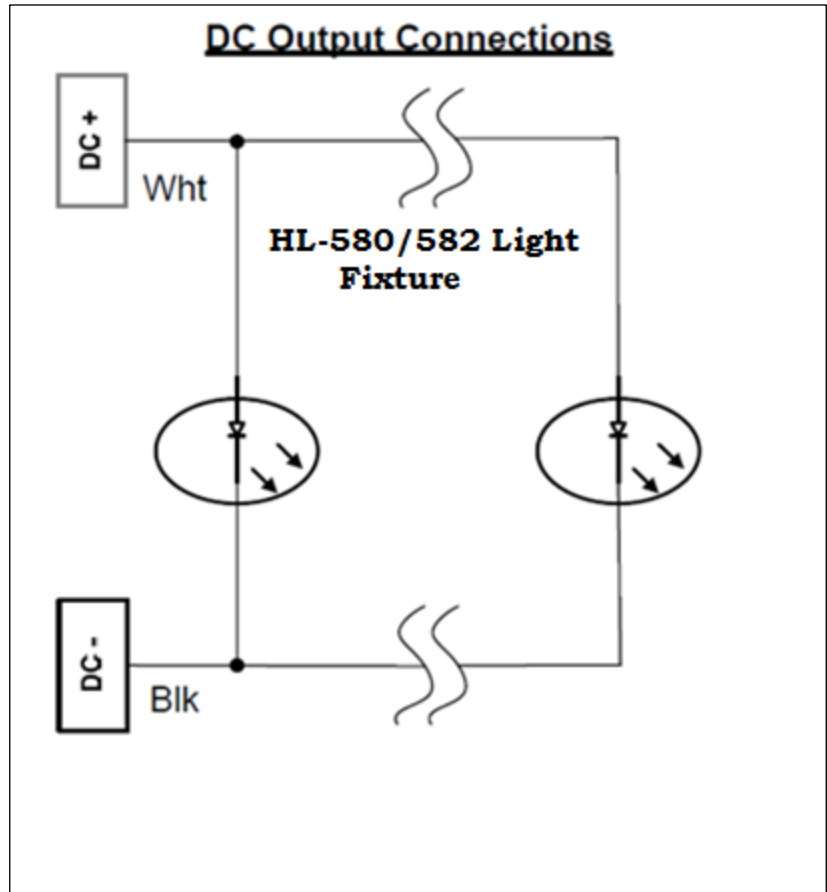



3.2c LED Lights DC Dimming and LED Lights DC Dimming with IR

Note that on the Dimming lights with IR, only the visible light is dimmable, the IR stays at the same intensity.

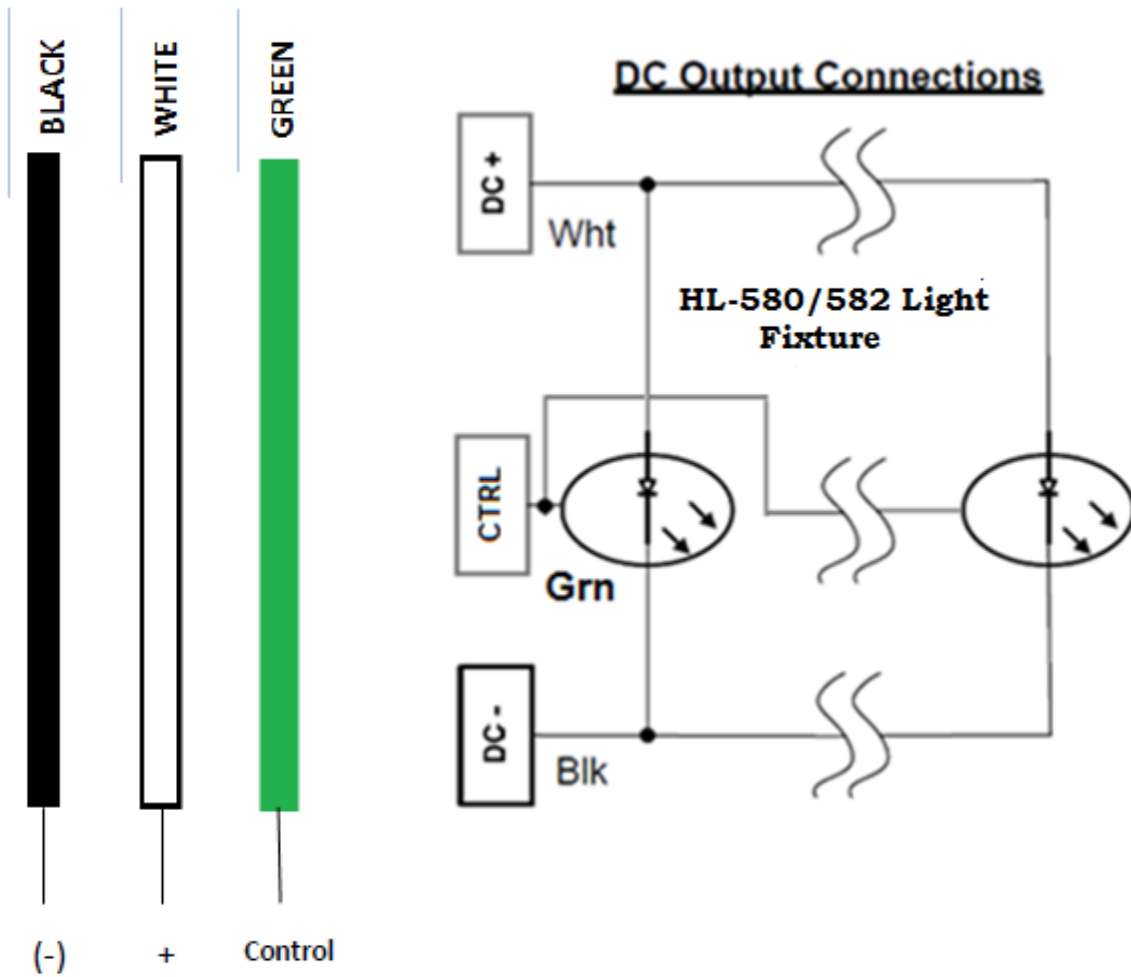



3.3 Installation

1. Position each light around the helipad perimeter as required by the site plans and specifications.
2. Refer to Figure 2 on page 7 for dimensions and distance in between holes.
3. Use four screws no larger than 3/8" (9.5mm). The length and type of screws will depend on the installation surface. Prior to bolting the fixtures, coat the bolt treads with marine grade anti-seize grease.

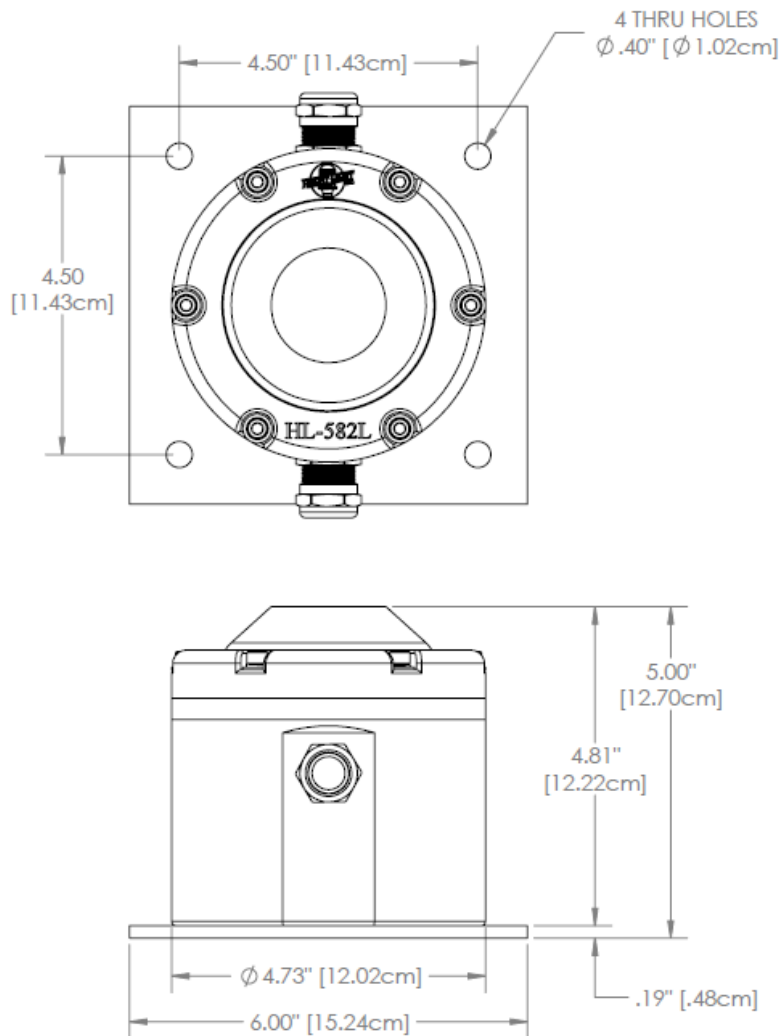

Figure 2



4. Maintenance

Recommended Practice:

- Verify the incoming power and confirm it matches the fixture’s rated voltage.
- Verify that there is no condensation inside the prism.
- Check for loose wire connections.
- Check for presence of corrosion or chipped paint.
- Remove existing vegetation that can affect the lights visual range.
- Clean lens with glass cleaner if lenses are dirty.
- Adjust and reposition any misaligned fixtures.
- Check for improper ground elevation.
- Periodically verify cord grips are not loose and provide a water tight seal.

5. Replacement Parts

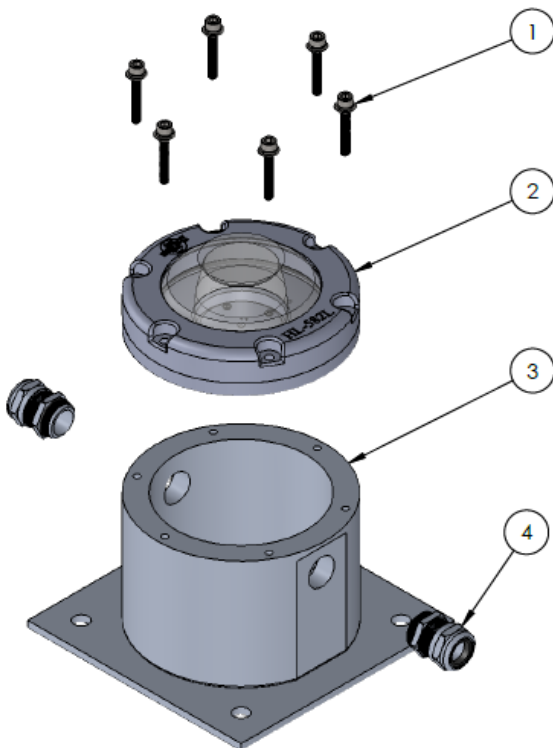

Item No.	Description	Part Number
1	Screw Kit 10-32 304 SS 1.25" Long	HL-582SCREWKIT
2	Upper Assembly	HL-582TOPKIT-X (x = color)
3	Lower Assembly	HL-582BOTTOMKIT
4	Cord Grip	27-CD20DA-BR
N/A	Gel Connector Kit	HL-582GCK



6. Limited Warranty

Duration of the Warranty: Flight Light Inc. warrants all of the goods which it has manufactured to be free of material defects for the following durations.

Lamps: For a period of 90 days from the date of shipment to Buyer. Product liability is limited to lamp replacement and does not include incidental labor.

FAA products: For a period of one year from the date of installation or two years from the date of shipment to Buyer.

LED Light Fixtures: For a period of 2 years from the date of shipment to Buyer. Complete Systems: Systems including at least one Flight Light Inc. Controller and one Flight Light Inc. LED Light Fixture, for a period of 5 years from the date of shipment to Buyer.

Buyer's Remedies: If any such goods are found to be materially defective within the warranty period, Flight Light Inc. agrees to attempt to repair, and if unable to repair, to replace the defective goods without charge to Buyer.

Buyer's remedy with respect to such goods is limited to repair or replacement. For goods not manufactured by FLI, Buyer agrees to accept as its sole remedy the warranty, if any, offered by the manufacturer or manufacturers of such goods. FLI makes no warranties, express or implied, other than those stated in this paragraph.

Warranty Exclusions: Flight Light Inc. shall not be liable under this warranty if any of the following conditions apply:

- 1) Unauthorized personnel attempt any repairs to Flight Light Inc. products without Flight Light Inc. consent.
- 2) Products are damaged by natural phenomenon, misuse, abuse, accident, alteration, or incorrect electrical current or voltage.
- 3) Products are improperly installed, or damaged in shipping.

Warranty Limitations

FLI makes no warranties, express or implied, other than those stated herein. FLI does not warranty the workmanship of the installer, damage caused by acts of nature, vandalism, improper installation, or damage caused by improper maintenance. The warranty period of LED fixtures covered under the 5-year system warranty is reduced to two years when fixtures are subjected to abrasive materials or chemicals. FLI reserves the right to either repair or replace any defective component covered under the terms of any of its warranties. FLI is not an engineering firm and makes no expressed or implied warranty as to the applicability of its products or systems in any specific situation, application or location: such decisions are the responsibility of the owner, design engineer and/ or others. Therefore, as to all goods sold by FLI, FLI hereby disclaims any implied warranty of merchantability or implied warranty of fitness for a particular purpose and Buyer agrees that FLI shall not be liable for any special, indirect, incidental, consequential or liquidated damages of any kind, whether the Buyer's or any other claim is based upon contract, tort or any other legal theory.