



Installation Manual 490



www.flightlight.com

1.800.806.3548 916.394.2800

Fax: 916.394.2809

2708 47th Avenue, Sacramento

CA 95822

Rev B .8/26/2019





Your Flight Light HL490 light fixtures have been designed to provide you years of service if you follow the recommendations outlined in this guide. Flight Light recommends any installation of our helideck fixtures follow NEC (National Electrical Code) 2014 and any other applicable local electrical codes.

Our fixture is compliant with:

- FAA AC 150/5390-2B Heliport Design Guide
- Exceeds FAA Engineering Brief 87 Specifications
- ICAO Annex 14, Volume II for TLOF
- Transport Canada TP14371, AGA 7.16
- Buy American Act
- IP67 Rating

Our newest feature: **Night Vision Compatibility**, allows pilots to see the lights while wearing Night Vision Goggles due to the IR (infrared) LED. The light is compatible with all generation goggles.

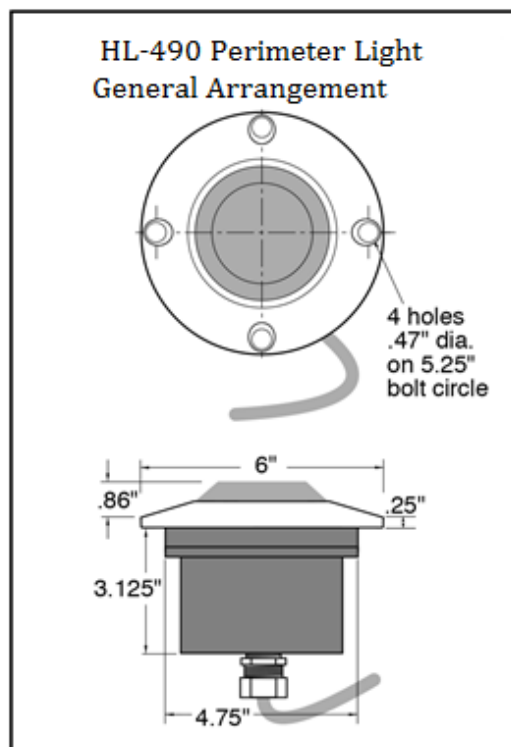



Contents

1. Introduction	1
1.1 About the manual.....	1
2. Safety Measures	2
3. Installation Procedures	3
3.1 Unpacking.....	3
3.2 Helideck Mounting Instructions	3
3.3 Heliport (In-Pavement) Mounting Instructions	4
3.4 Tools and Supplies Needed	8
4. Wiring	9
4.1 AC LED Lights and AC with IR LED Lights.....	10
4.2 DC LED Lights and DC with IR LED Lights	11
4.3 LED Lights DC Dimming.....	12
5. Maintenance & Troubleshooting	13
6. Replacement Parts	14
7. LED Replacement	15
8. Warranty	16



1. Introduction

The Flight Light model 490 is a 304 stainless steel nitric acid passivated light suitable for marine environments. The passivated stainless steel body makes it corrosion resistant, increases wear resistance, increases abrasion resistance and flame resistance. The 490 light is available for use as a helideck or helipad light in order to ensure proper visual guidance. Available in VDC and VAC, the light conforms to the FAA requirements.

For surface applications the inset lights should always be installed using the Flight Light 6" base can and following the below instructions as well as the local NEC codes.

The Base Can must be purchased separately.

The light comes with a male cord attached to the fixture and the matching female cord packed in the box with the light.

The installation and maintenance should be done by authorized personnel only.

For questions or guidance during the installation process, please contact our office as engineers and technician are always available to help you.

Phone number: 1-800-806-3458
916-394-2800

OR sent an email request to sales@flightlight.com

1.1 About the manual

This manual contains the needed instructions to complete a successful installation. It also contains information regarding the additional needed tools and products. Note that not all the items that will be needed to complete the installation are included with the light.

See the maintenance section for information regarding replacement parts and troubleshooting guidelines.



2. Safety Measures

You must know whether your heliport lighting system is powered by AC or DC before installing the fixture. AC LED models work on a range of 100 to 240VAC. DC models operate from 10 to 30VDC. The lights are designed to be installed in a parallel circuit, which maintains a constant voltage and brightness for all lights.

Ensure power is off before installing or servicing heliport fixtures!

Follow the local NEC code!

Make sure the equipment is rated and approved for the environment in which you are intending to use it. Do not operate this equipment in humid, flammable, or explosive environments unless it has been rated for safe operation in these environments.

Use only electrical wire of sufficient gauge and insulation to handle the rated current and voltage demand.

Route electrical wiring along a protected path. Make sure they will not be damaged by moving equipment.

Protect components from harsh environment conditions.

Protect equipment with safety devices as specified by applicable safety regulations.

Before starting this equipment, check all safety interlocks, fire –detection systems, and protective devices such as panels and covers. Make sure all devices are fully functional. Do not operate the system if these devices are not working properly.

Never operate equipment with a known malfunction.

Do not attempt to operate or service electrical equipment if standing water is present.

Do not touch exposed electrical connections on equipment while the power is ON!

Wiring and electrical design should be authorized by an electrical contractor.

Wiring connections and wire splices must be done in a waterproof junction box.



3. Installation Procedures

3.1 Unpacking

Each inset light is packed in its own box 8" x 8" x 8", together with the additional female plug. Carefully remove the light from its box and inspect for damages. If any damages are found, file a claim with the carrier. Also remove the female plug from the box, if this is missing please contact Flight Light Inc. Installing the light without the matching plug will void the warranty. Removal of the L823 male plug from the light will allow water to get into the lighting fixture and void the warranty.

3.2 Helideck Mounting Instructions

1. For surface mounting, cut a 4.75" diameter hole in the helideck. Place the HL-490 fixture in the hole and secure with four ¼ - 20 stainless steel flathead screws.
2. For mounting under a deck, use an adapter ring or pieces of uni-strut.
3. The incoming cable from the helideck should connect to a weatherproof junction box. All luminaire electronic parts are inside a weatherproof enclosure. A water immersion test is performed on all HL-490 light fixtures to ensure moisture sealing before shipping.





3.3 Heliport (In-Pavement) Mounting Instructions

1. For mounting in pavement, a base can must be used for support. Flight Light provides a 6" Diameter base can that the light fits in.
2. Proper drainage is critical for longevity of the fixture since water intrusion can destroy the electronics inside the fixture. The fixture is weatherproof and some water is expected to enter the base can, but provisions must be made to drain the water. Figure 1 outlines the suggested installation for proper drainage:

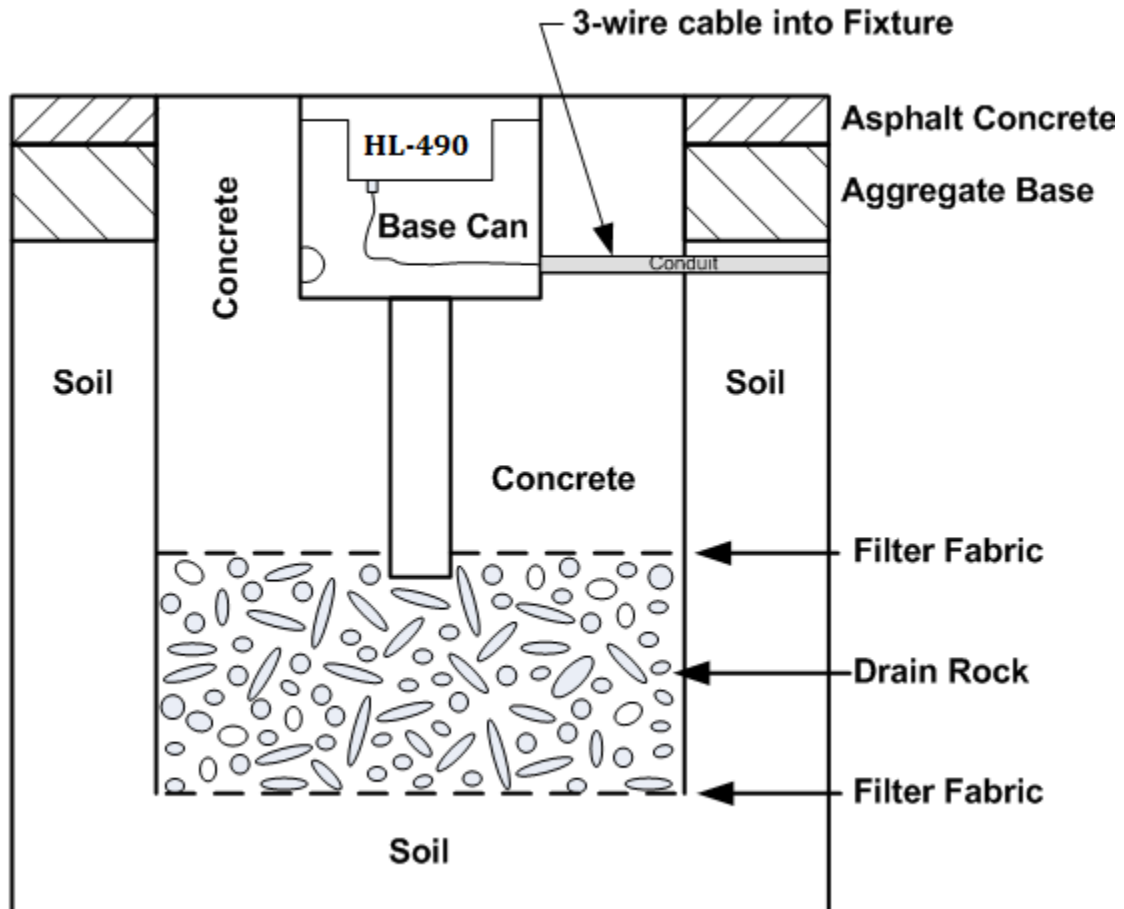

Figure 1



- I. The Drain Rock should be encased in a filter fabric material to avoid soil infiltration
- II. The recommended depth of drain rock unit varies dependent upon the type of existing soils.
- III. Where existing soils are granular and permeable the depth of the drain rock unit can be limited to 1 foot.
- IV. Where existing soils are fine graded and have low permeability the depth of the drain rock unit should be increased to 3 feet or greater to provide a reservoir for short term retention.

One possible layout for the light fixtures and their associated Junction Boxes is shown in Figure 2. It is recommended to place the Junction Boxes on a small slab of concrete to insulate them from the soil and align them with the conduit level.

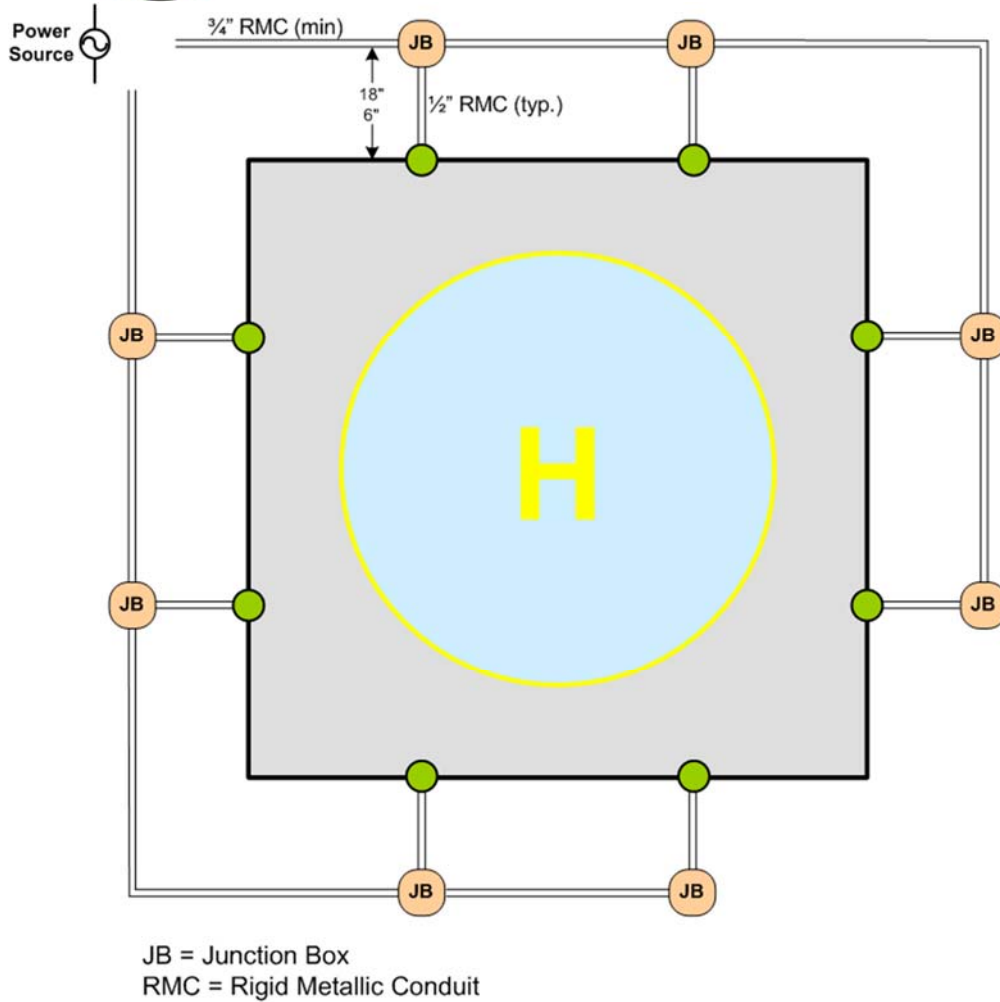

Figure 2

Installation requires a 5 $\frac{1}{4}$ " Bolt circle base can to house the light fixture. The base can is grounded through the fixture mounting bolts.

Junction boxes are not provided by Flight Light Inc. The base cans are for support only and are not considered a waterproof junction box.



The base can comes with the following accessories:



Plywood cover 6" Diameter $\frac{3}{4}$ " Thick
4 x Bolts
2 x Grommets

The plywood cover imitates the height of the casting of the 490 fixture- .25".



The 490 is a semi flush fixture with an inclined casting. This will stand above the level of the pad by .86"

Once the light is set over the gasket, use the four bolts received to secure it into the base can. Silicone is recommended to be used to seal the gap in between the fixture and the concrete.



Make sure the male and female plugs are properly connected so a water seal is being created!

Use Dielectric grease on the connectors before plugging them together.

Wrap the mated connectors inside the can with electrical tape for added moisture protection.

3.4 Tools and Supplies Needed

Besides the accessories Flight Light Inc. is providing, the following items may be needed to complete a successful installation:

1. Dielectric grease
2. Junction box
3. Silicone
4. Electrical Tape



4. Wiring

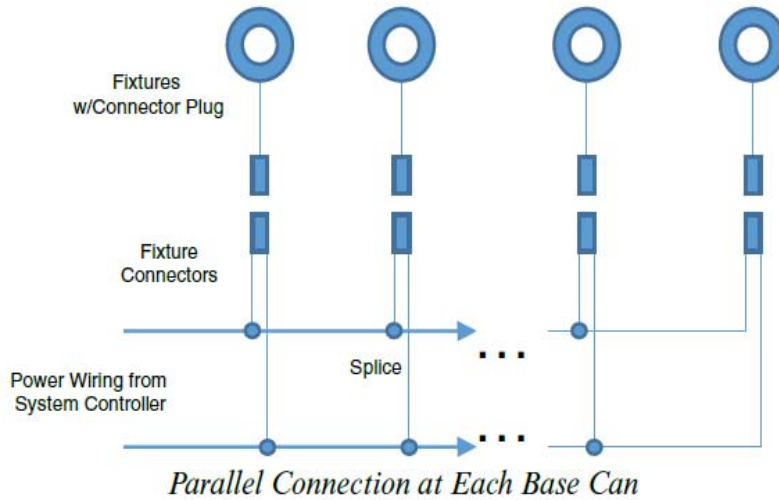

The installation of lights is to be done in a parallel circuit with the splice in a secure, waterproof junction box. Junction boxes are not provided with the lights. The Flight Light base cans are not a waterproof enclosure.

The gauge of the electrical wire is to be calculated by the electrical engineer and should be sufficient to handle the rated current and voltage demand.



4.1 AC LED Lights and AC with IR LED Lights

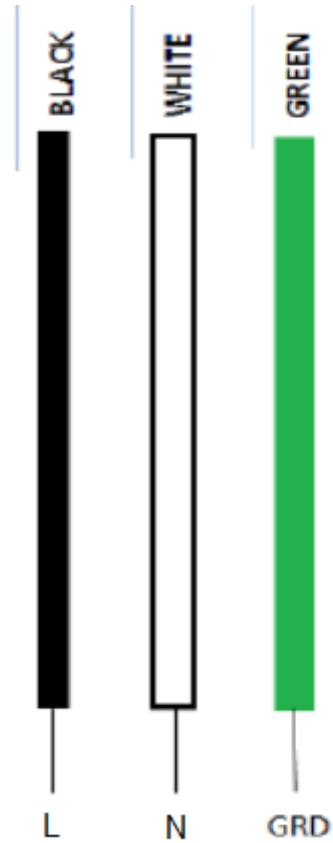
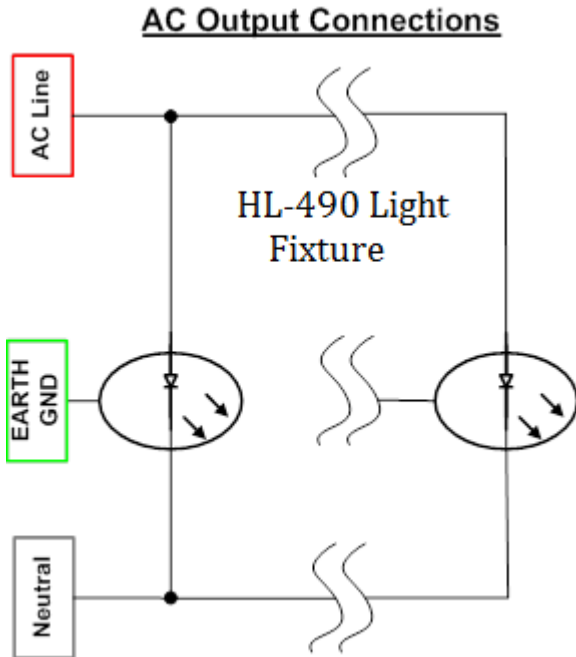

WARNING! Do not look at Infrared Light Fixtures while they are ON! Infrared light output is hazardous to your eyes.



4.2 DC LED Lights and DC with IR LED Lights

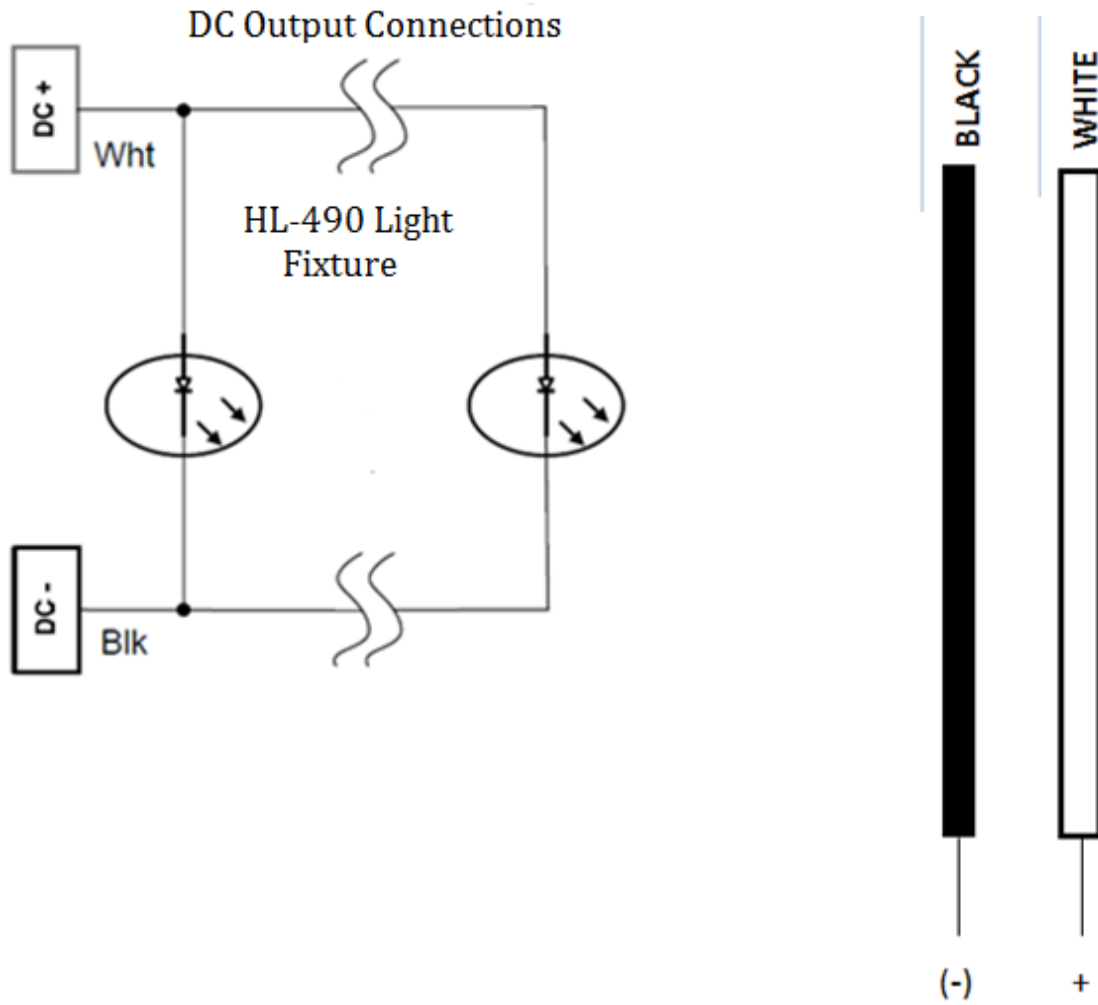

WARNING! Do not look at Infrared Light Fixtures while they are ON! Infrared light output is hazardous to your eyes.



4.3 LED Lights DC Dimming

DC Output Connection

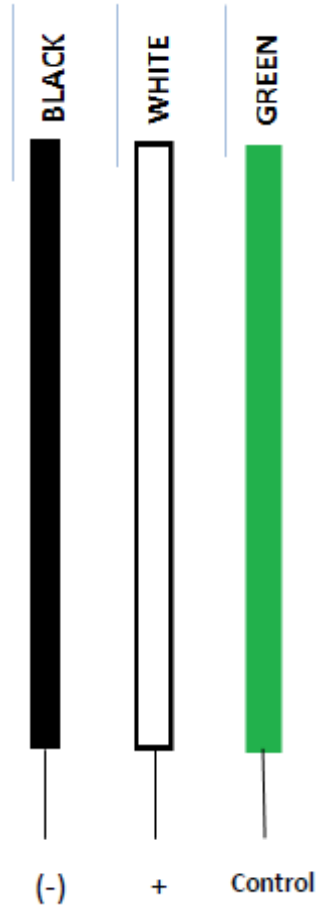
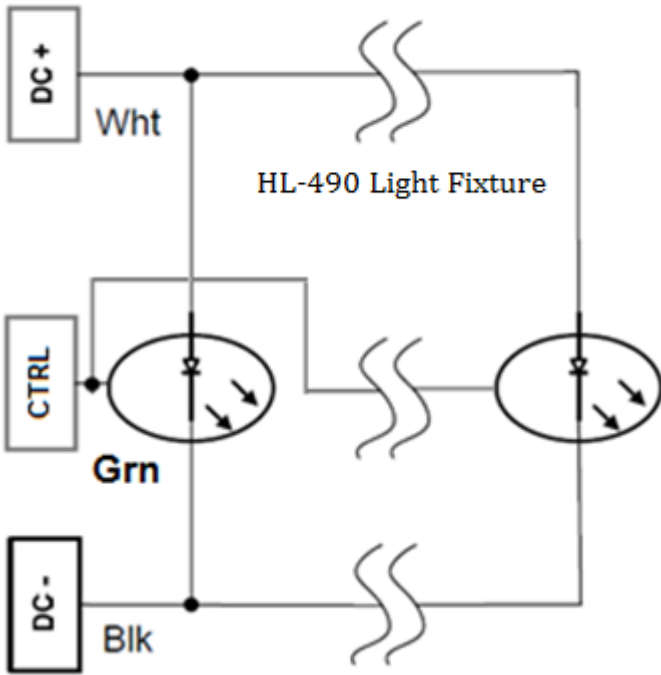



5. Maintenance & Troubleshooting

The following general maintenance procedures will help ensure maximum performance and long component life:

- Lenses should be cleaned periodically as an accumulation of dirt, can decrease light output.
- Line voltage should be checked at the fixture and compared with the power supply to be sure it is within the prescribed limits.
- Make certain polarity is correct for DC light fixtures
- Be sure the fixtures are properly grounded.



6. Replacement Parts

1.....	HL-490L Top Casting.....	16-490MN
2.....	Prism Gasket	65-033090
3.....	Clear Prism Dome	80-016080
4.....	Prism Clamp Teflon Gasket	27-492CG
5.....	O-ring	27-9396K175
6.....	HL-490L Prism Clamp	16-490PLTMN
7.....	8-32 316SS 0.75" Long Screws	NS-91500A197
8.....	AC LED Replacement Kit.....	HL-XL9KITB-AC*
ALT ...	DC LED Replacement Kit	HL-XL9KITB-DC*
ALT ...	UL LED Replacement Kit.....	HL-XL9KITB-UL*
ALT ...	Dimming LED Replacement Kit	HL-XL9KITB-D*
9.....	No. 6 304SS Screws.....	NS-S0632X025PPMSP
10.....	HL-490L Bottom Casting.....	16-490-BOTTOM2 5/8M
11.....	6-32 316SS 0.5" Long Screw.....	NS-91500A148
12.....	Pipe Fitting.....	HA-PP000001
13.....	UL Cable Assembly	20-CABLE-ASSY-UL
14.....	Cable Assembly with Male Plug.....	20-CABLE-ASSY**
15.....	Cable Assembly with Female Plug	TRC-0395MR7Q-0.5**

* For LED Replacement Kits, X = Color
 ** Not UL listed.

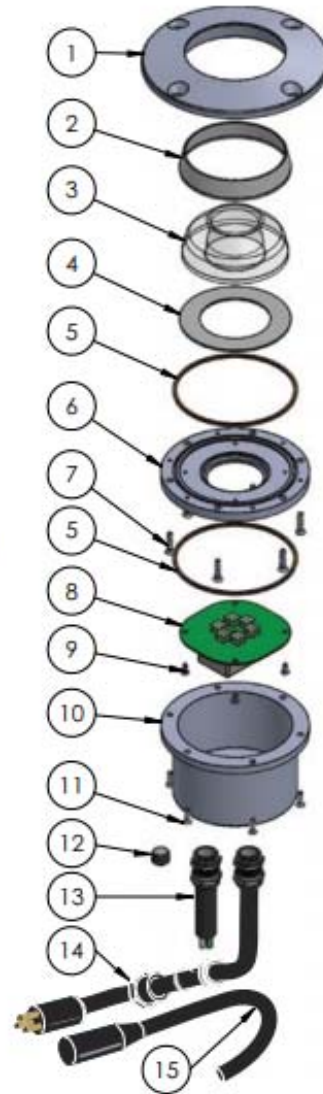

IR Lights are not field serviceable. They need to be returned to factory for repairs and LED board replacement.



7. LED Replacement

The LED Replacement Kit consist on the following:

Bottom casting, Cord Grip and Male cord sealed in the bottom casting, LED Driver and LED Board.

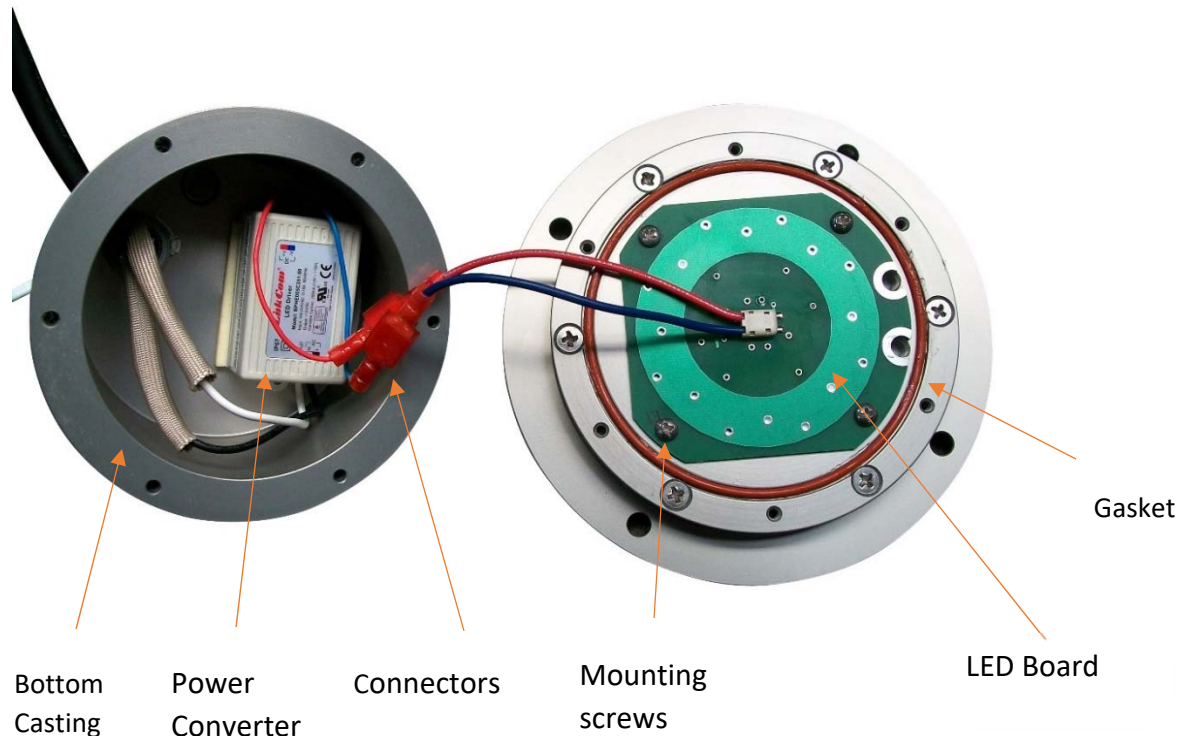

To properly replace the LED board and to insure correct seal, follow the below instructions:

- Turn the light upside down and remove the four bottom cover screws
- Unplug connectors coming from the power converter to the LED board
- Remove the 4 mounting screws that hold the LED board in place
- Remove LED board
- Discard the LED board, bottom casting with the existing cord and the power converter
- Remove the blue film from the new LED board and put it in place
- Reinstall mounting screws for the LED board
- Connect the LED board to the power converter
- Make sure the bottom cover gasket is seated properly
- Install the four bottom cover screws to close the fixture



8. Warranty

Duration of the Warranty: Flight Light Inc. warrants all of the goods which it has manufactured to be free of material defects for the following durations.

Lamps: For a period of 90 days from the date of shipment to Buyer. Product liability is limited to lamp replacement and does not include incidental labor.

FAA products: For a period of one year from the date of installation or two years from the date of shipment to Buyer.

LED Light Fixtures: For a period of 2 years from the date of shipment to Buyer. Complete Systems: Systems including at least one Flight Light Inc. Controller and one Flight Light Inc. LED Light Fixture, for a period of 5 years from the date of shipment to Buyer.

Buyer's Remedies: If any such goods are found to be materially defective within the warranty period, Flight Light Inc. agrees to attempt to repair, and if unable to repair, to replace the defective goods without charge to Buyer.

Buyer's remedy with respect to such goods is limited to repair or replacement. For goods not manufactured by FLI, Buyer agrees to accept as its sole remedy the warranty, if any, offered by the manufacturer or manufacturers of such goods. FLI makes no warranties, express or implied, other than those stated in this paragraph.

Warranty Exclusions: Flight Light Inc. shall not be liable under this warranty if any of the following conditions apply:

- 1) Unauthorized personnel attempt any repairs to Flight Light Inc. products without Flight Light Inc. consent.
- 2) Products are damaged by natural phenomenon, misuse, abuse, accident, alteration, or incorrect electrical current or voltage.
- 3) Products are improperly installed, or damaged in shipping.

Warranty Limitations

FLI makes no warranties, express or implied, other than those stated herein. FLI does not warranty the workmanship of the installer, damage caused by acts of nature, vandalism, improper installation, or damage caused by improper maintenance. The warranty period of LED fixtures covered under the 5-year system warranty is reduced to two years when fixtures are subjected to abrasive materials or chemicals. FLI reserves the right to either repair or replace any defective component covered under the terms of any of its warranties. FLI is not an engineering firm and makes no expressed or implied warranty as to the applicability of its products or systems in any specific situation, application or location: such decisions are the responsibility of the owner, design engineer and/ or others. Therefore, as to all goods sold by FLI, FLI hereby disclaims any implied warranty of merchantability or implied warranty of fitness for a particular purpose and Buyer agrees that FLI shall not be liable for any special, indirect, incidental, consequential or liquidated damages of any kind, whether the Buyer's or any other claim is based upon contract, tort or any other legal theory.