



HL-860L LED Heliport Perimeter Light

Compliance

- ICAO Annex 14, Vol II, 1999
ICAO Type: Touchdown and lift-off area perimeter light for helicopter non-instrument and non-precision approaches.
- Exceeds FAA AC 150/5390-2D Appendix G Specifications
- IP67 Compliant

Applications

Our heliport perimeter lights provide an LED based solution to the ICAO touchdown and lift-off area perimeter style of steady-burning lights. The lights are currently available with green, blue, red, clear, yellow or infrared LEDs operating at 100-277 VAC, 12-48 VDC, or 10-30 VDC (dimming). Each configuration is available as original equipment or as direct lens/lamp field retrofit to existing conventional light bases. This fixture may be mounted on a base plate, stake or Low Surface Mount, sold separately.

Features

- LED life rated up to 70,000 hours
- 95% less power than an equivalent incandescent light
- 2.4 - 4 watts power consumption
- Available with green, blue, red, clear, yellow or infrared LEDs
- 3-Step Dimming Controller to minimize nighttime glare available
- Weather/corrosion resistant machined aluminum construction with aviation yellow powder coat finish and stainless steel hardware
- IP Rating: IP67
- Self contained wiring compartment eliminates additional boxes
- Resistant to shock and vibration
- Direct replacement for existing incandescent lighting
- 5 year warranty

Visible/Infrared LED Option

Common LED lights can pose a hazard to pilots using Night Vision Goggles (NVGs). This is due to the fact that NVGs typically use filters to block cockpit lighting from saturating the imaging system. This has the unintended effect of making LED lights invisible to pilots. In response, we have incorporated NVG friendly technology into our perimeter light, giving pilots using night vision goggles unmatched visibility of the helipad touchdown and lift-off area (TLOF).

Dimming Option

With the dimming option, the lights can be dimmed at night to reduce glare. Three brightness levels can be selected. The dimming option is only available with a Flight Light 3-Step Dimming Controller.



HL-860L LED Heliport Perimeter Light
(base plate sold separately)

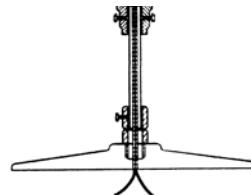

Base Mounted
8.5" or 12"
Base Plate
(sold separately)



Stake Mounted
30" Angle-Iron
Mounting Stake
(sold separately)



Low Surface Mount
No frangible
coupling



Shallow Base Mounted

With this mounting option the overall installed height is less than 8 inches, complying with AC 150/5390-2B requirements for raised perimeter lights. 5" Shallow Base and 8.5" Base Plate sold separately.



Ordering Codes

Fixture	Output	Power ³	Mounting	Fixture Options
HL-860L	G: Green (std) ¹ B: Blue R: Red C: Clear Y: Yellow IR: Infrared ²	AC: 100-277 VAC DC: 12-48 VDC DCD: 10-30 VDC Dimming	8: 8" (no frangible coupling) 14: 14" (standard) 24: 24" (extended) 30: 30" (extended) LSM: Low Surface Mount (no frangible coupling) ⁴	1: 1.5" Frangible Coupling (FL-FC1.5) 2: 2" Frangible Coupling (FL-FC2.0) H: High Temperature ⁵ MT: Marine Treated

Wire Color Guide

BLACK	WHITE	GREEN	RED	BLACK	GREEN
L	(N)	GRD	+	(-)	GRD
100-277 VAC			12-48 VDC		

¹ Green is currently the recommended color for heliport perimeter lights.

² Infrared must be used in conjunction with visible LEDs. Infrared does not dim with the "DCD" dimming option.

³ Power Consumption: DC (12-48VDC) 2.4W; DC IR (12-48VDC) 3.4W; AC (120VAC) 3W; AC IR (120VAC) 4W.

⁴ LSM mounting option: 11-1/4" overall fixture height.

⁵ For locations with high temperatures above +131°F (+55°C).

Spare Parts

Part Number	Description
HL-860LED-X-AC	100-277 VAC LED Replacement Light Head
HL-860LEDIR-X-AC	100-277 VAC LED NV Infrared Replacement Light Head
HL-860LED-X-DC	12-48 VDC LED Replacement Light Head
HL-860LEDIR-X-DC	12-48 VDC LED NV Infrared Replacement Light Head



Marine Treated Option:

- Recommended for harsh, high-salt coastal and marine environments.
- Protects fixture finish from salt damage and prevents corrosion.
- 3-Step Powder Coat: 1) Primer, 2) Epoxy powder base coat and glossy polyester gray (RAL 7030) powder finish coat, 3) Oven curing.



X = Output color

Mounting Details

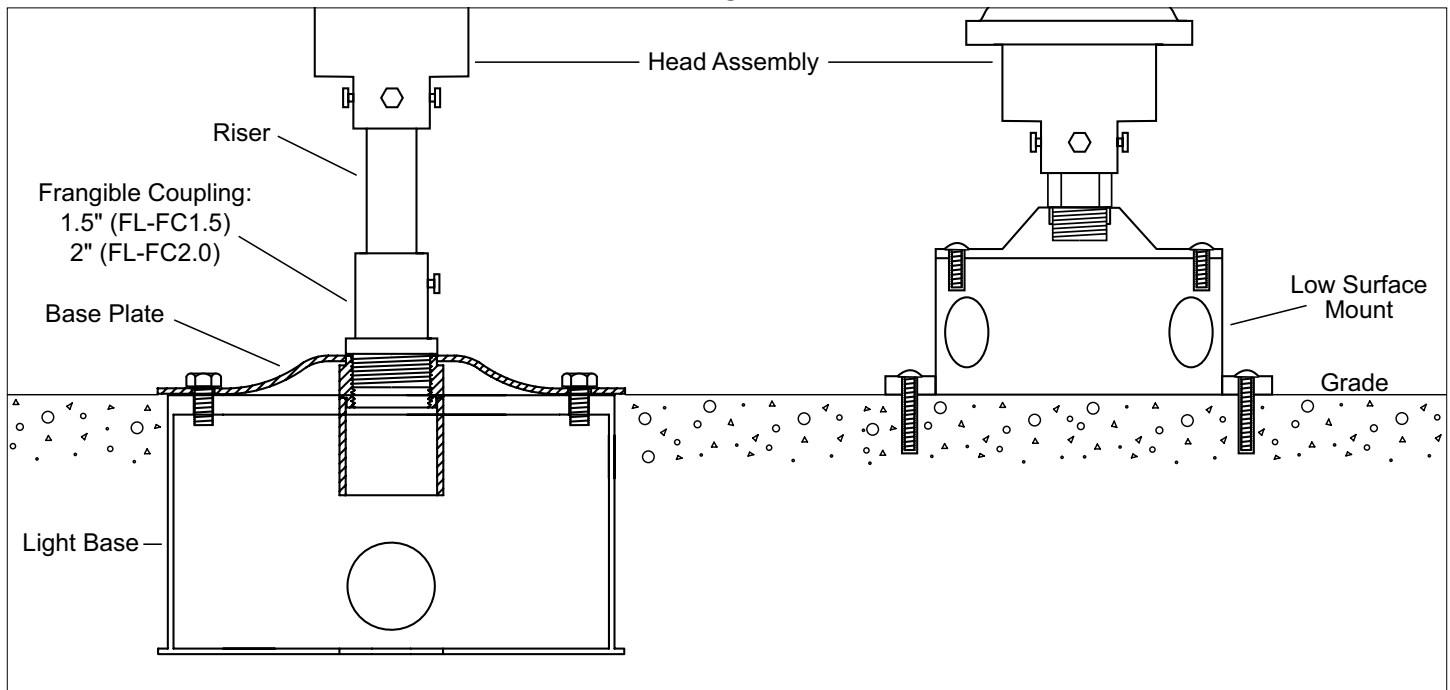

+1.800.806.3548 USA
+1.916.394.2800 Worldwide

www.flightlight.com
sales@flightlight.com

Flight Light Inc., 2708 47th Ave.
Sacramento, CA, 95822, USA



Base Plate for L868AA 5" Shallow Base

Specifications

- Dimensions: 8.5" diameter x .25" thick
- Bolt Circle: 7.25"
- Material: Hot rolled steel
- Finish: Aviation yellow powder coat
- Includes (6) 3/8-16 x 1" stainless steel hex head cap screws
- Part #: BA-1932AA-25 (2" NPS)
- BA-1935AA-25 (1-1/2"-12 UNF)



Low Surface Mount

Rain and snow won't hurt these corrosion-resistant boxes. They feature a powder coating and are UL listed and CSA certified.

The boxes are aluminum and have NPSM (National Pipe Straight Mechanical) threaded hubs in the back and sides for secure connection to conduit and fittings. They come with closure plugs for unused hubs, a grounding screw, and attachable mounting lugs. The boxes may be mounted horizontally and vertically.

Single-device (1 gang) boxes hold one toggle switch, GFCI, duplex receptacle, or other electrical device; two-device (2 gang) boxes hold two.

Specifications

- Number of Hubs: 5
- Hub Trade Size*: 1/2"
- Overall Size: Diameter 4-5/16", Height 2-1/4"
- Capacity: 16.5 cu. in.
- Finish: powder coating, gray

* Note: Trade size refers to an industry designation for conduit and fittings and is not an actual measurement. When selecting a box, match the trade size of the conduit.

