



INSTALLATION MANUAL 690



www.flightlight.com

1.800.806.3548 1.916.394.2800

sales@flightlight.com

2708 47th Avenue, Sacramento

CA 95822-3806





Your Flight Light 690L light fixtures have been designed to provide you years of service if you follow the recommendations outlined in this guide. Flight Light recommends any installation of our helideck fixtures follow NEC (National Electrical Code) 2014 and any other applicable local electrical codes.

Our fixture is compliant with:

- FAA AC 150/5390-2C Heliport Design Guide
- Exceeds FAA Engineering Brief 87 Specifications
- ICAO Annex 14, Volume II for TLOF and FATO
- CE and RoHS Certified
- IK10 Impact Protection
- IP68 Ingress Protection

Power Consumption:

- HL-690L-X-AC (100-240VAC) – 12W
- HL-690L-X-AC3 (277VAC) – 12W
- HL-690L-X-DC (12-30VDC) – 12W
- HL-690L-X-DCD (10-30VDC) Dimming – 12W Max

Our newest feature: **Night Vision Compatibility**, allows pilots to see the lights while wearing Night Vision Goggles due to the IR (infrared) LED. The light is compatible with all generation goggles.

Fixture Dimensions

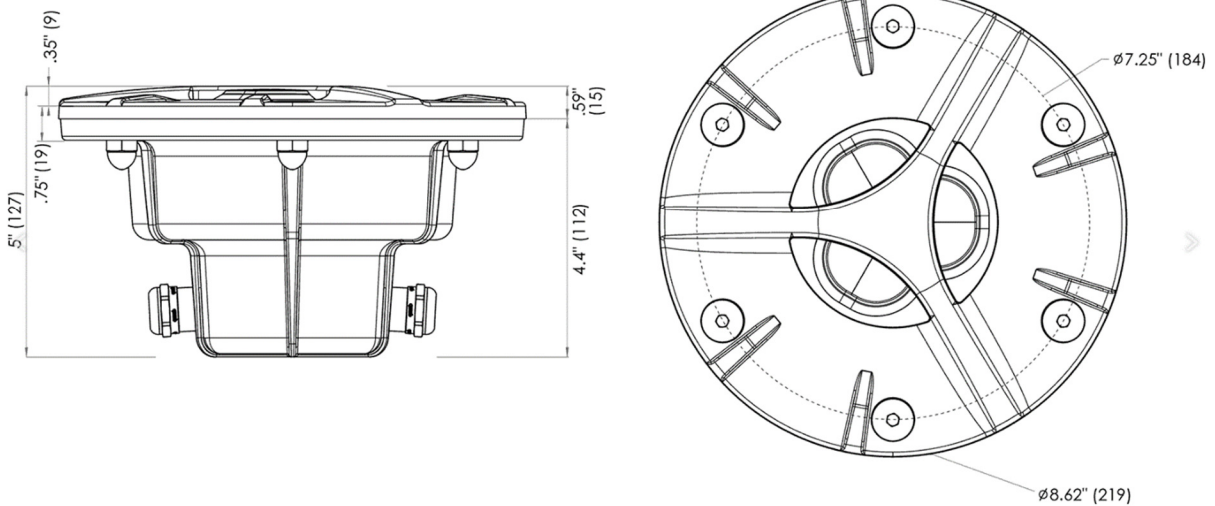



Contents

1. Introduction	1
2. Safety Measures	3
3. Installation Procedures	4
3.1 Installation in a base can	4
3.1.1 Unpacking	4
3.1.2 Drainage System Requirements	4
3.1.3 Base Can Installation	5
3.1.4 Setting the fixture	11
3.1.5 Tools and Supplies Needed	12
3.2 Installation in concrete, without base can	12
4. Wiring	16
G1C Cable Layout	16
G2C Cable Layout	16
G3C Cable Layout	16
4.1 LED Lights AC (100-240VAC or 100-277VAC for AC3 model only) and LED lights AC with IR	18
4.2 LED Lights DC and LED Lights DC with IR	19
4.3 LED Lights DC Dimming	20
5. Maintenance and Troubleshooting	21
5 Replacement Parts	22
6 Limited Warranty	23



1. Introduction

The Flight Light model 690 is a painted aluminum light suitable for helipad applications to ensure proper visual guidance. Available in VDC and VAC, the light conforms to the FAA requirements and ICAO TLOF (green) and FATO (white).

The helipad inset lights should always be installed using the Flight Light 8" OD base can and following the below instructions as well as the local NEC codes.

The Base Can must be purchased separately and **is only for support, not a waterproof junction box. See below example.**



The black junction box is only an example of the junction box needed for the installation. This is not included with the light.

The splicing of the wire must be done inside a waterproof junction box for wire protection.

Warranty will be voided if open wires or connections are left exposed and prone to water intrusion.

The light comes with one or two entries. The light with one entry has one male cord attached and the matching female cord packed in the box with the light. The light with two entries has one male and one female cord attached to the light, with the corresponding male/female cords packed in the box with the light.



The installation and maintenance should be done by authorized personnel only.

This manual contains the needed instructions to complete a successful installation. Failure to install the system properly will negatively impact the performance of the system, shorten its life, and may void the manufacturer's warranty. We recommend that a copy of the manual be given to both the design engineer and the installer of your system, well in advance of the actual installation.



The major steps covered in this manual include:

In-pavement Installation

1. Installation with a base can

- Proper Placement of Fixtures
- Drainage System Requirements and Design
- Base Can Installation guidelines

2. Installation without a base can

For questions or guidance during the installation process, please contact our office as engineers and technician are always available to help you.

Phone number: 1-800-806-3458

1-916-394-2800

OR send an email request to sales@flightlight.com



2. Safety Measures

You must know whether your heliport lighting system is powered by AC or DC before installing the fixture. AC models work on a range of 100 to 240VAC if LED or our AC3 LED fixtures work on 277VAC. DC models operate from 10 to 30VDC. The lights are designed to be installed in a parallel circuit, which maintains a constant voltage and brightness for all lights.

Ensure power is off before installing or servicing heliport fixtures!

Follow the local NEC code!

Make sure the equipment is rated and approved for the environment in which you are intending to use it. Do not operate this equipment in humid, flammable, or explosive environments unless it has been rated for safe operation in these environments.

Use only electrical wire of sufficient gauge and insulation to handle the rated current and voltage demand.

Route electrical wiring along a protected path. Make sure they will not be damaged by moving equipment.

Protect components from harsh environment conditions.

Protect equipment with safety devices as specified by applicable safety regulations.

Before starting this equipment, check all safety interlocks, fire –detection systems, and protective devices such as panels and covers. Make sure all devices are fully functional. Do not operate the system if these devices are not working properly.

Never operate equipment with a known malfunction.

Do not attempt to operate or service electrical equipment if standing water is present.

Do not touch exposed electrical connections on equipment while the power is ON!

Wiring and electrical design should be authorized by an electrical contractor.

Wiring connections and wire splices must be done in a waterproof junction box.



3. Installation Procedures

3.1 Installation in a base can

3.1.1 Unpacking

Each inset light is packed in its own box 9"x 9" x 5", together with the additional plug(s). Carefully remove the light from its box and inspect for damages. If any damages are found, file a claim with the carrier. Also remove the plug(s) from the box, if this is missing please contact Flight Light Inc. Installing the light without the matching plug(s) will void the warranty. Removal of the L823 male or female plug from the light will allow water to get into the lighting fixture and void the warranty.

3.1.2 Drainage System Requirements

The truism that water and electricity don't mix holds for Aviation Installations. Helipads pavement is subject to many sources of moisture, the most serious of which is ground water. The Flight Light lighting system is designed to prevent water and water vapor from making contact with electrical conductors, contacts and connections. Fixtures used in the FL system employ seals that prevent moisture from entering the light fixture. Fixtures are IP68 rated. The connectors used are waterproof and provide connection between the fixture, and control system without fear of electrical shorting to ground. However, water within the base cans, left for long periods of time, may create problems. Standing water in the base can is especially undesirable in colder climates because of damage that can be done when water freezes and expands. To prevent problems caused by standing water in the base cans a proper drainage system must be designed and prior to the electrical installation of the fixtures and pouring of concrete. Failure to install a proper drainage system may result in damage to the system components.



3.1.3 Base Can Installation

There is no standard way to build a helipad. Each project includes its own individual variables. Some of these are:

- The type of paving material to use
- Anticipated loads and traffic
- The kind of subsoil
- The kind of subbase to use
- The need for special treatment of the subsoil
- Water conditions at the site
- Other environmental conditions
- The need for concurrent operations during construction
- Funds available

Only the consultant familiar with all the variables of a given site can properly design the project. Once the specific design is produced appropriate methods can be followed to successfully install the in-pavement lighting system.

The purpose of the following procedure is to provide installers with guidance on how to install the base cans.

The base cans come with the following accessories:



- Plywood cover 8" Diameter 3/4" Thick
- 2 x Bolts
- 1 x Gasket
- 2 x Grommets
- 2 x PVC Fittings for the drain hole

The plywood cover imitates the height of the casting of the 690 fixture- .75".

1. The base cans come with the cover bolted into the base can and the accessories inside. Remove the cover and get the accessories out. The plywood cover has to be placed back on the base can for concrete pouring.



For Existing pavements:

2. To install base cans, begin by core drilling holes in the locations specified by the project engineer (*typically 12"-14" in diameter, the depth will be per terrain and/or suggestion of the civil engineer/contractor*). Saw cuts should then be made to allow room for the fixture power cables (*typically 3" deep x 1/2" wide*). Saw cuts are typically made in line with the centers of the conduit holes.
3. Prepare the drainage system specified by the design engineer. *(see figure 1 on page 7 and notes)*
4. Install the rubber grommets in each of the side holes.



5. Install the base can drain fittings provided (pictured below) into each base can drain hole. Run 1-1/2" size pipe, schedule 40 PVC, into the fittings of the base can. Pipe length should be cut so the pipe, when positioned over the drain, extends approximately 3" to 4" into the drain rock.



External Fitting (Left) and Internal Fitting



Base Can with Fitting Installed

6. Use of mounting jig is recommended for proper alignment of base cans. First, place the plywood cover on the base can, and then mount the mounting jig to the base can with the two bolts that fit into the base can bolt holes.



7. After the mounting jig is attached, suspend the base can so the top of the plywood cover is flush with the surface of the pavement. Note: When the fixture is installed the top of the fixture will mount flush with the surface of the pavement.
8. After the base cans are installed, test the drainage system by pouring water into the installed base can at each fixture location. Pour enough water to verify that the underlying ground is absorbing the water. If the base can is not draining properly, modifications to the drainage system will be necessary. In this case, consult with your project engineer before proceeding.
FAILING TO HAVE PROPER DRAINAGE WILL DAMAGE THE LIGHT. FLIGHT LIGHT INC WILL NOT COVER SUCH WATER DAMAGES UNDER WARRANTY.
9. Once satisfied with drainage system, move on to the installation of the fixture power cables.
10. Install the fixture cables. Run fixture power cables to each base can, one black wire, and one white wire, to each can. The green ground wire comes attached to the fixture's metal housing with a screw (factory installed). Attach the green wire to the base can with a screw to the base can's ground strap to properly ground fixture.
11. Make all wire connection and splices in a secure waterproof enclosure/junction box. The base can provided by Flight Light is not considered a waterproof enclosure. Failure to secure the connections of the wires will allow water to infiltrate and damage the complete light assembly.
12. After all cabling has been completed, encase the base cans and drainage system in concrete. It is recommended that at least 6" of concrete be used below the base. Fill saw cuts with Traffic Loop Sealant, or equivalent



Figure 1: Base Can Installation – Core Drill and Saw Cut

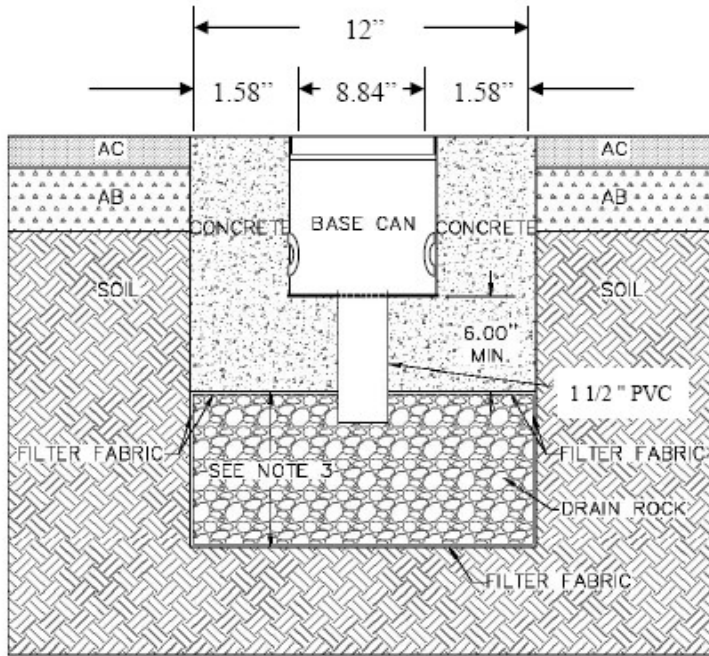

Notes:

1. Drain rock shall be graded from 1 inch to ¼ inch.
2. Drain rock shall be encased in a filter fabric material to avoid soil infiltration into the drain rock.
3. Recommended depth of drain rock unit varies dependent upon the type of existing soils.
 - a. Where existing soils are granular and permeable the depth of the drain rock unit can be limited to 1 foot.
 - b. Where existing soils are fine graded and have low permeability the depth of the drain rock unit should be increased to 3 feet or greater to provide a reservoir for short term retention. Refer to engineering plans for the requirements specified by the project engineer.
4. Concrete shall be 3/8 inch maximum aggregate mix, use a minimum of seven sacks of cement per cubic yard of concrete and poured from a height of approximately 5 inches above the can. Concrete should only be poured from one side. Vibrate or rod concrete to completely fill the area below and on all sides of the base can. When concrete is visible on the side opposite to the side that concrete is being poured from, pouring can commence from alternate locations.

Abbreviations: Asphalt Concrete (AC), Aggregate Base (AB)



For new installations:

For a completely new helipad, before pouring the concrete, create the appropriate drainage system. See Figure 1 on page 7 and notes.

1. Install the rubber grommets in each of the side holes.



2. Install the base can drain fittings provided (pictured below) into each base can drain hole. Run 1-1/2" size pipe, schedule 40 PVC, into the fittings of the base can. Pipe length should be cut so the pipe, when positioned over the drain, extends approximately 3" to 4" into the drain rock.





3. After the base cans are installed, test the drainage system by pouring water into the installed base can at each fixture location. Pour enough water to verify that the underlying ground is absorbing the water. If the base can is not draining properly, modifications to the drainage system will be necessary. In this case, consult with your project engineer before proceeding.
FAILING TO HAVE PROPER DRAINAGE WILL DAMAGE THE LIGHT. FLIGHT LIGHT INC WILL NOT COVER SUCH WATER DAMAGES UNDER WARRANTY.
4. Once satisfied with drainage system, move on to the installation of the fixture power cables.
5. Install the fixture cables. Run fixture power cables to each base can, one black wire, and one white wire, to each can. The green ground wire comes attached to the fixture's metal housing with a screw (factory installed). Attach the green wire to the base can with a screw to the base can's ground strap to properly ground fixture.
6. Make all wire connection and splices in a secure waterproof enclosure/junction box. The base can provided by Flight Light is not considered a waterproof enclosure. Failure to secure the connections of the wires will allow water to infiltrate and damage the complete light assembly.
7. After all cabling has been completed, encase the base cans and drainage system in concrete. It is recommended that at least 6" of concrete be used below the base. Fill saw cuts with Traffic Loop Sealant, or equivalent.



3.1.4 Setting the fixture

Once the base can is position in concrete, remove the bolts and plywood cover.



Flight Light Inc. base cans are galvanized steel FAA approved L868AA.

1. Using electrician's tape, make three wraps around the pigtail connector and fixture plug.
2. Prior to bolting down the fixtures, coat the mounting flange of each base can and bolt treads with marine grade anti-seize grease, like Corrosion Block or equivalent.
3. Bolt the fixtures to the base cans using the (4) stainless steel bolts provided.
4. Fill-in both, the area between the fixture and base can wall and the area in the bolt well, with a silicon sealant such as RTV silicon sealant, or equivalent.



Make sure the male and female plug are properly connected so a water seal is being created!

Use Dielectric grease on the connectors before plugging them together.

Wrap the mated connectors inside the can with electrical tape for added moisture protection.



3.1.5 Tools and Supplies Needed

Besides the accessories Flight Light Inc. is providing, the following items may be needed to complete a successful installation:

1. Mounting Jig
2. Dielectric grease
3. Junction box
4. Silicone

3.2 Installation in concrete, without base can

The following installation process is not recommended by FAA. The FAA recommends installing heliport fixtures in base cans. Changing or not completing the described installation process can result in suspension of warranty.

Each light is shipped with:

4X Bolts: HEX 3/8-16 X 1"

2X Bolts: HEX 3/8-16 X 5/8"

4X Nuts: 3/8-16, Cap Nut

2X Clamps





1. After deciding the location where the fixture will be installed, drill a hole having a minimum diameter of 9.1" (230mm) and a minimum depth of 5.1" (130mm).

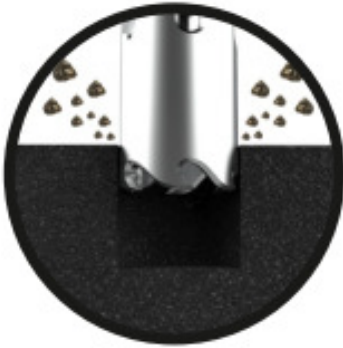

2. Using a disk cutter, open a connection between the holes with 1.2" (30mm) width and 5.1" (130 mm) depth.





3. Brush any debris or dust from the hole resulting from drilling.



4. Dry the hole with a blowtorch to remove any moisture that may compromise the adhesion and effectiveness of the grout.

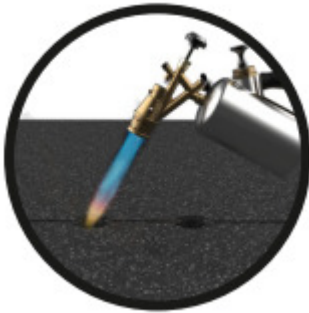

5. Add the installation accessory to each fixture that will help align and keep the fixture in place during the grout drying time. This accessory will be removed at the end of the installation.

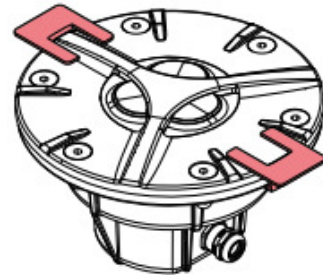
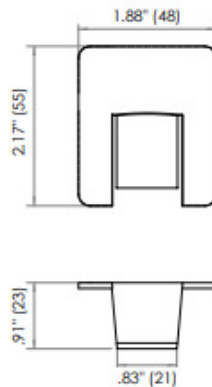



6. Pour +/- 15.4 Lb (+/- 7Kg) of ultraflow 4000/8 grout in the hole and insert the fixture. Remove any excess grout.



7. The grout drying time may change depending on weather conditions. Consult the grout data sheet for more information. After the grout has dried, the top part of the installation accessory should be broken and removed.





4. Wiring

G1C Cable Layout

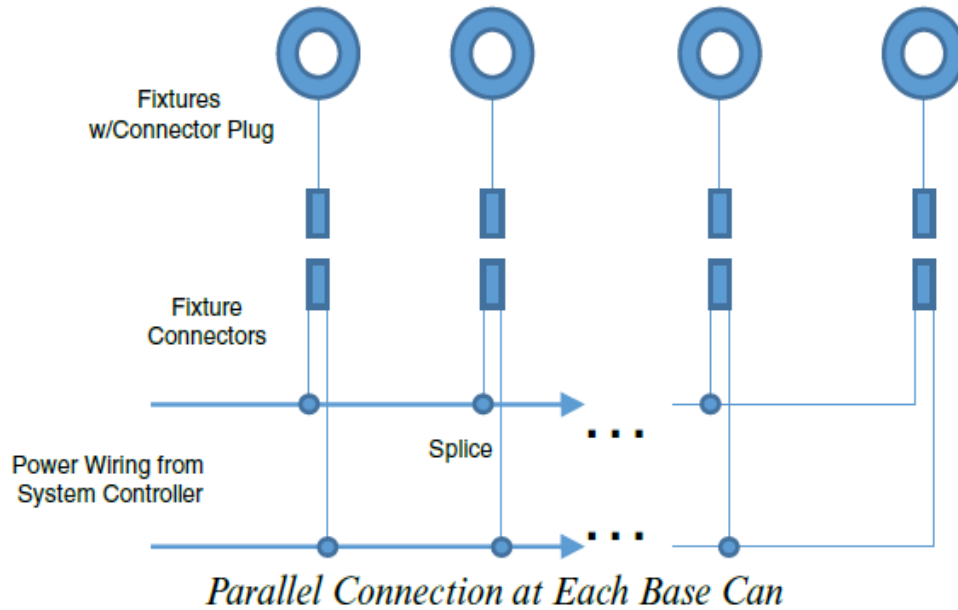

G2C Cable Layout

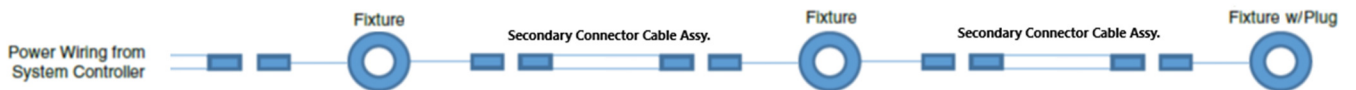

G3C Cable Layout

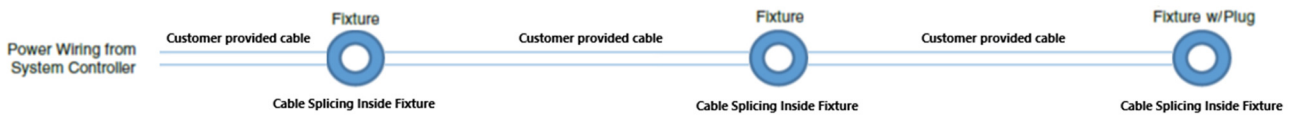



The installation of lights is to be done in a parallel circuit with the splice in a secure, waterproof junction box. Junction boxes are not provided with the lights. The Flight Light base cans are not a waterproof enclosure.

The gauge of the electrical wire is to be calculated by the electrical engineer and should be sufficient to handle the rated current and voltage demand.



The black junction box is only an example of the junction box needed for the installation.

The splicing of the wire must be done inside a waterproof junction box for wire protection.

Warranty will be voided if open wires or connections are left exposed and prone to water intrusion.



4.1 LED Lights AC (100-240VAC or 100-277VAC for AC3 model only) and LED lights AC with IR

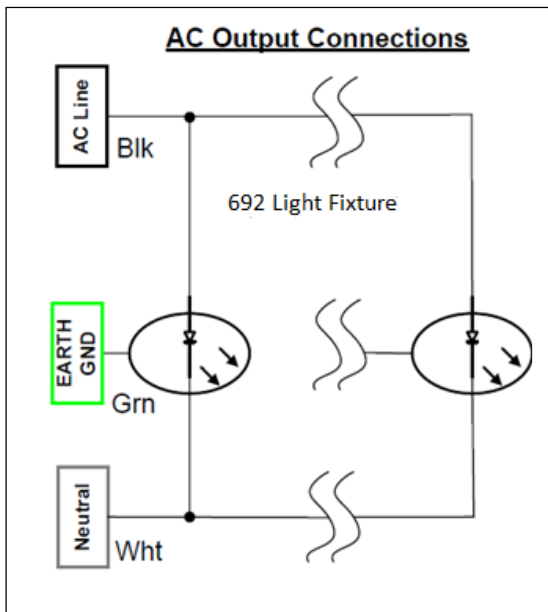
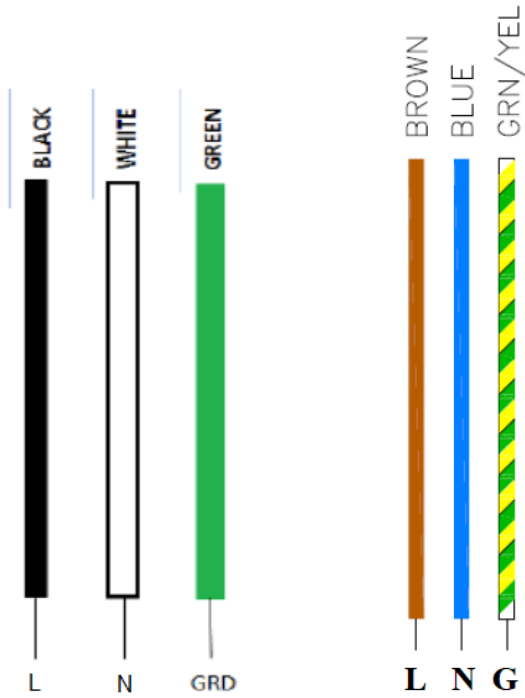



There is a ground lug inside the base can for your earth/ground connection (green or green/yellow wire).

4.2 LED Lights DC and LED Lights DC with IR

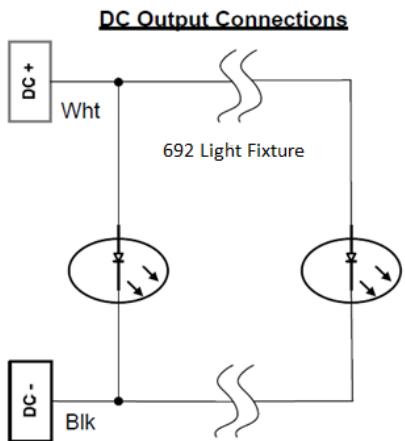
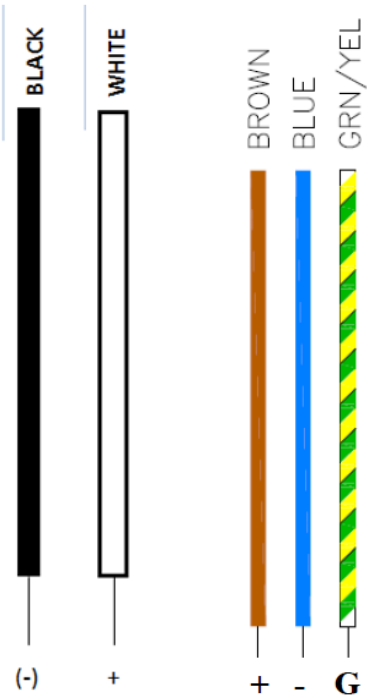



4.3 LED Lights DC Dimming

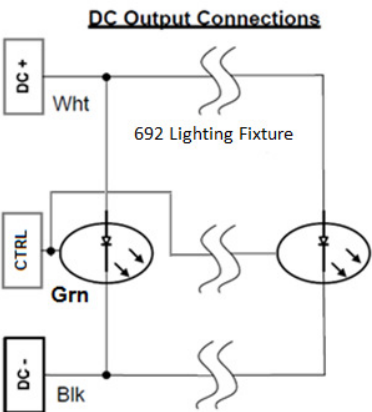
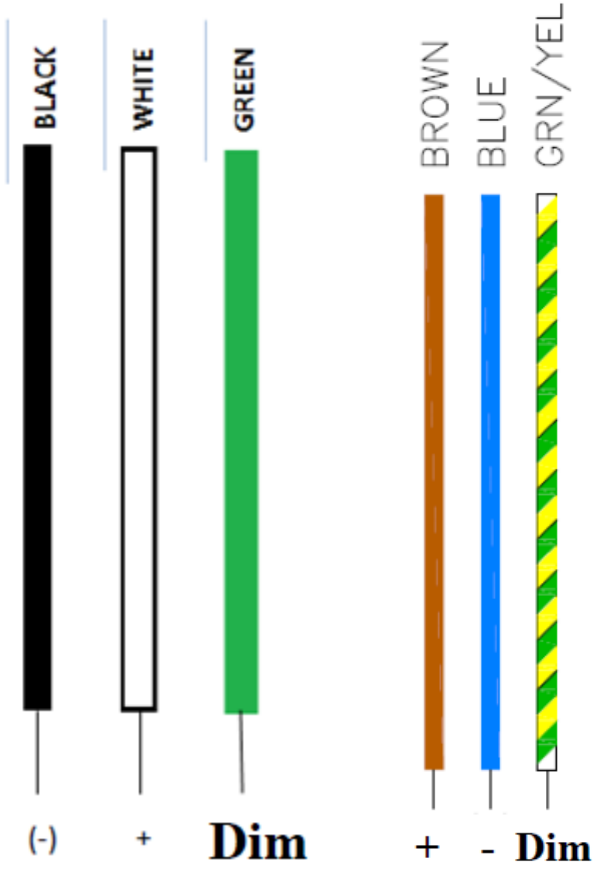



5. Maintenance and Troubleshooting

The following general maintenance procedures will help ensure maximum performance and long component life:

- Lenses should be cleaned periodically as an accumulation of dirt, can decrease light output.
- Line voltage should be checked at the fixture and compared with the power supply to be sure it is within the prescribed limits.
- Make certain polarity is correct for DC light fixtures
- Be sure the fixtures are properly grounded.
- If LEDs don't turn on, verify with multimeter, that there is voltage (12VDC) on the LED wires that connect to the LED driver board.
- If LEDs don't turn on, verify with multimeter, that there is voltage (12-24VDC) on the LED driver board input connector for a DC fixture and (120-277VAC) for an AC powered fixture.



5 Replacement Parts

Common Replacement Parts

Ref.	Description	Part #
1	Top Casting Stainless Steel	HL-690L-TOP
2	AC Light Module	HL-690/2L-XAC*
	DC Light Module	HL-690/2L-XDC*
	DCD Light Module	HL-690/2L-XDCD*
	AC+IR Light Module	HL-690/2L-XIRAC*
	DC+IR Light Module	HL-690/2L-XIRDC*
	DCD+IR Light Module (infrared does not dim)	HL-690/2L-XIRDCD*
3	O-Ring	HL-690/2L-ORING
4	Bottom Casting	HL-690/2L-BOTTOM
5	2-Pin Male Connector	TRC-10518-114D02
6	3-Pin Male Connector (DCD Dimming only)	80-013031
7	2-Conductor Female Connector	TRC-10519-07-021
8	3-Conductor Female Connector (DCD Dimming only)	80-012022
9	Installation Accessories for Non-base Installation (2 per fixture)	HL-690/2-IA

* For light modules, X = Color (G = Green, B = Blue, R = Red, W = White, Y = Yellow)

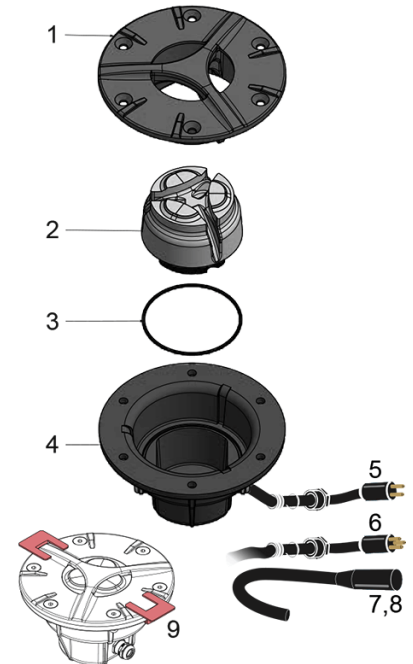



6 Limited Warranty

Duration of the Warranty: Flight Light Inc. warrants all of the goods which it has manufactured to be free of material defects for the following durations.

Lamps: For a period of 90 days from the date of shipment to Buyer. Product liability is limited to lamp replacement and does not include incidental labor.

FAA products: For a period of one year from the date of installation or two years from the date of shipment to Buyer.

LED Light Fixtures: For a period of 2 years from the date of shipment to Buyer. Complete Systems: Systems including at least one Flight Light Inc. Controller and one Flight Light Inc. LED Light Fixture, for a period of 5 years from the date of shipment to Buyer.

Buyer's Remedies: If any such goods are found to be materially defective within the warranty period, Flight Light Inc. agrees to attempt to repair, and if unable to repair, to replace the defective goods without charge to Buyer.

Buyer's remedy with respect to such goods is limited to repair or replacement. For goods not manufactured by FLI, Buyer agrees to accept as its sole remedy the warranty, if any, offered by the manufacturer or manufacturers of such goods. FLI makes no warranties, express or implied, other than those stated in this paragraph.

Warranty Exclusions: Flight Light Inc. shall not be liable under this warranty if any of the following conditions apply:

- 1) Unauthorized personnel attempt any repairs to Flight Light Inc. products without Flight Light Inc. consent.
- 2) Products are damaged by natural phenomenon, misuse, abuse, accident, alteration, or incorrect electrical current or voltage.
- 3) Products are improperly installed, or damaged in shipping.

Warranty Limitations

FLI makes no warranties, express or implied, other than those stated herein. FLI does not warranty the workmanship of the installer, damage caused by acts of nature, vandalism, improper installation, or damage caused by improper maintenance. The warranty period of LED fixtures covered under the 5-year system warranty is reduced to two years when fixtures are subjected to abrasive materials or chemicals. FLI reserves the right to either repair or replace any defective component covered under the terms of any of its warranties. FLI is not an engineering firm and makes no expressed or implied warranty as to the applicability of its products or systems in any specific situation, application or location: such decisions are the responsibility of the owner, design engineer and/ or others. Therefore, as to all goods sold by FLI, FLI hereby disclaims any implied warranty of merchantability or implied warranty of fitness for a particular purpose and Buyer agrees that FLI shall not be liable for any special, indirect, incidental, consequential or liquidated damages of any kind, whether the Buyer's or any other claim is based upon contract, tort or any other legal theory.



WARNING:

MOUNTING BASE CAN IS NOT A WATER-PROOF JUNCTION BOX.

WIRE SPlicing MUST BE DONE INSIDE A UL APPROVED WATER-
PROOF JUNCTION BOX.

WARRANTY WILL BE VOID IF INSTALLATION IS NOT DONE PROPERLY.