



Flight Light Inc.
 2708 47th Ave.
 Sacramento, California, U.S.A.
 95822-3806



+1.800.806.3548
 +1.916.394.2800

www.flightlight.com
sales@flightlight.com

Flight Light Inc.
Heliport Perimeter Light
FAA Compliant L-860

Heliport Perimeter Light

Low intensity constant voltage elevated perimeter light helps mark heliport touchdown and lift-off area (TLOF). The fixture consists of a colored Fresnel lens (globe) mounted on an aviation yellow powder coated cast aluminum lamp housing. The powdercoat finish complies with the US Military Standard Salt Fog Test conducted per MIL-STD-810E, Method 509.3, Procedure 1 for corrosion resistance. The lamp is secured by an O-ring seal and clamp band. The upper assembly mounts on a 1" EMT extension into the 1.5" NF aluminum breakable coupling. An optional 2" NPS breakable coupling is available. All of the hardware is stainless steel.

This fixture may be mounted on a base plate, junction box or stake, sold separately. The light is furnished with wire leads for wiring in the field. Most of the replacement parts are compatible with other manufacturers; consult Flight Light with specific inquiries. With a low initial cost and up to 8,000 hours rated lamp life (69W), this fixture is the most economical light we offer.



Low Surface Mount
 No frangible coupling



Stake Mounted
 30" Angle-Iron Mounting Stake (sold separately)

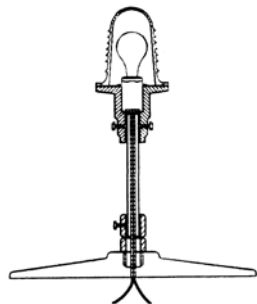

Base Mounted
 8.5" or 12" Base Plate (sold separately)



Heliport Perimeter Light
 (base plate sold separately)

Ordering Codes

Fixture	Globe Color ¹	Lamp & Power	Mounting	Fixture Options	Compliance
FL-860	G: Green	60A2: 60W, A21, 230V	8: 8" (no frangible coupling)	1: 1.5" Frangible Coupling (FL-FC1.5)	MT: Marine Treated
	Y: Yellow	69A: 69W, A21, 120V	9.5: 9.5" (ICAO FATO) ²	2: 2" Frangible Coupling (FL-FC2.0)	
	R: Red	116A: 116W, 120V ²	14: 14" (standard)		
	B: Blue	116A2: 116W, 230V ²	24: 24" (extended)		
	C: Clear		30: 30" (extended)		
			LSM: Low Surface Mount (no frangible coupling) ³		

Shipping Weight: 3.2 lb./1.5 kilo., Volume: 0.5 cu. feet/0.01 cu. meters

1. Green is currently the recommended color for heliport perimeter lights. Other colors, solid and split lens, available upon request.

2. ICAO FATO compliant configuration: Clear globe, 116W lamp, 9.5" mounting height.

3. LSM mounting option: 11-1/4" overall fixture height.

Shallow Base Mounted

With this mounting option the overall installed height is less than 8 inches, complying with AC 150/5390-2B requirements for raised perimeter lights. 5" Shallow Base and 8.5" Base Plate (sold separately)

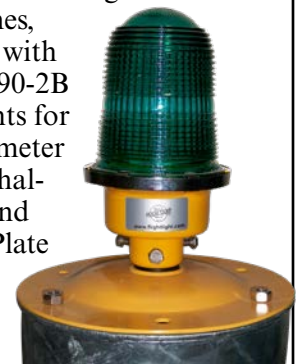

Visit our web site: www.flightlight.com



Flight Light Inc.
2708 47th Ave.
Sacramento, California, U.S.A.
95822-3806



+1.800.806.3548
+1.916.394.2800

www.flightlight.com
sales@flightlight.com

Flight Light Inc.
Heliport Perimeter Light
FAA Compliant L-860

Common Replacement Parts

61-861G	L861-Glass Green
61-861Y	L861-Glass Yellow
61-80001*	L861-Clamp Band (stainless steel)
61-80002	L861-O-Ring Gasket
FL-FC1.5	L861-1.5" Frangible Coupling (metal)
FL-FC2.0	L861-2" Frangible Coupling (metal)
61-80004	Medium Base Socket
LA-15386IP	Lamp: 60 Watt, A21, 230V (1,000 rated life)
LA-12496-1	Lamp: 69 Watt, A21, 120V (8,000 rated life)

* Clamp band only compatible with Flight Light fixtures.



Marine Treated Option:

- Recommended for harsh, high-salt coastal and marine environments.
- Protects fixture finish from salt damage and prevents corrosion.
- 3-Step Powder Coat: 1) Primer, 2) Epoxy powder base coat and glossy polyester gray (RAL 7030) powder finish coat, 3) Oven curing.

Heliport Perimeter Light Mounting Details

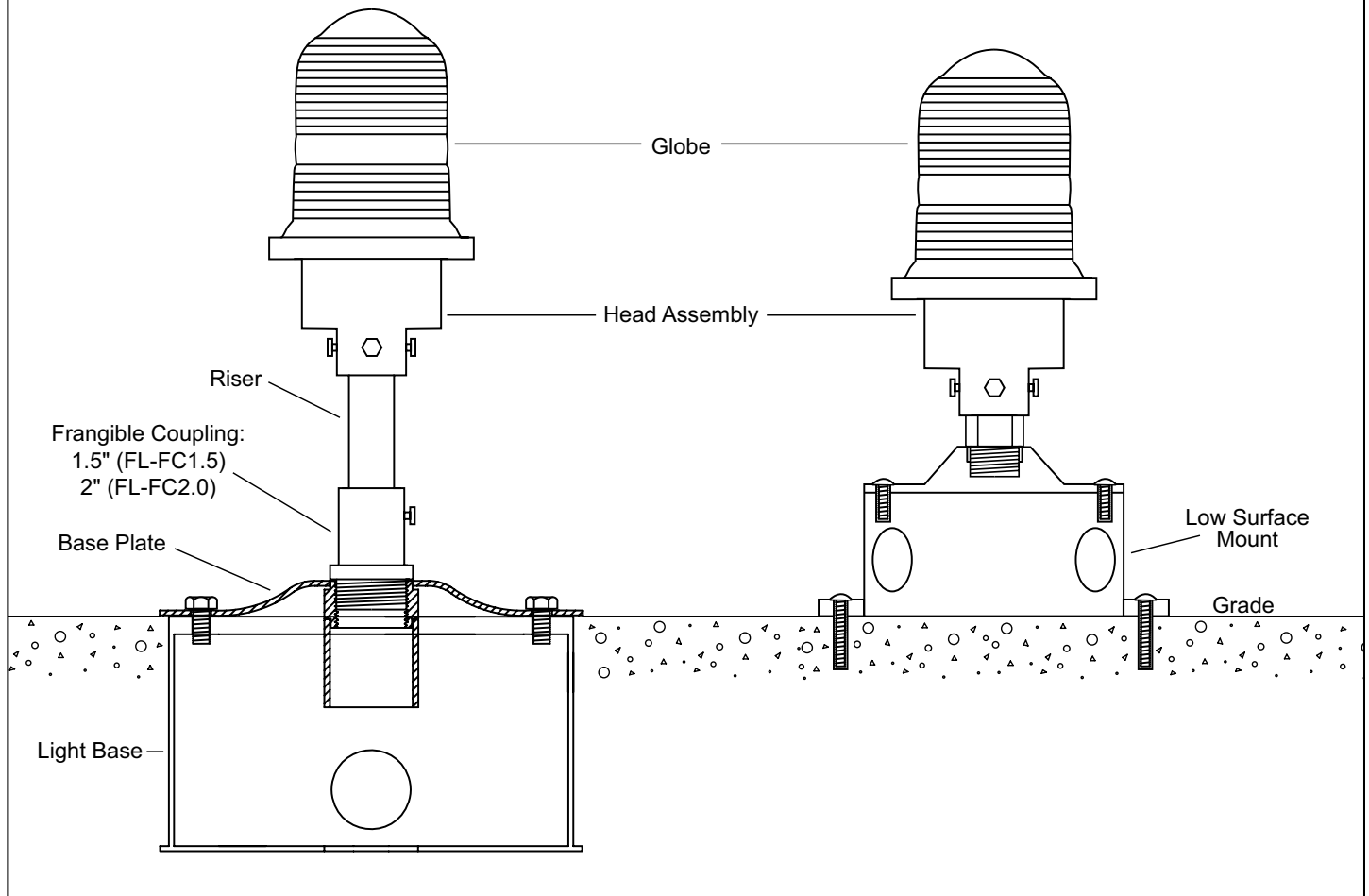

Visit our web site: www.flightlight.com



Flight Light Inc.
 2708 47th Ave.
 Sacramento, California, U.S.A.
 95822-3806



Flight Light Inc.
 Heliport Perimeter Light
 FAA Compliant L-860

+1.800.806.3548
 +1.916.394.2800

www.flightlight.com
 sales@flightlight.com

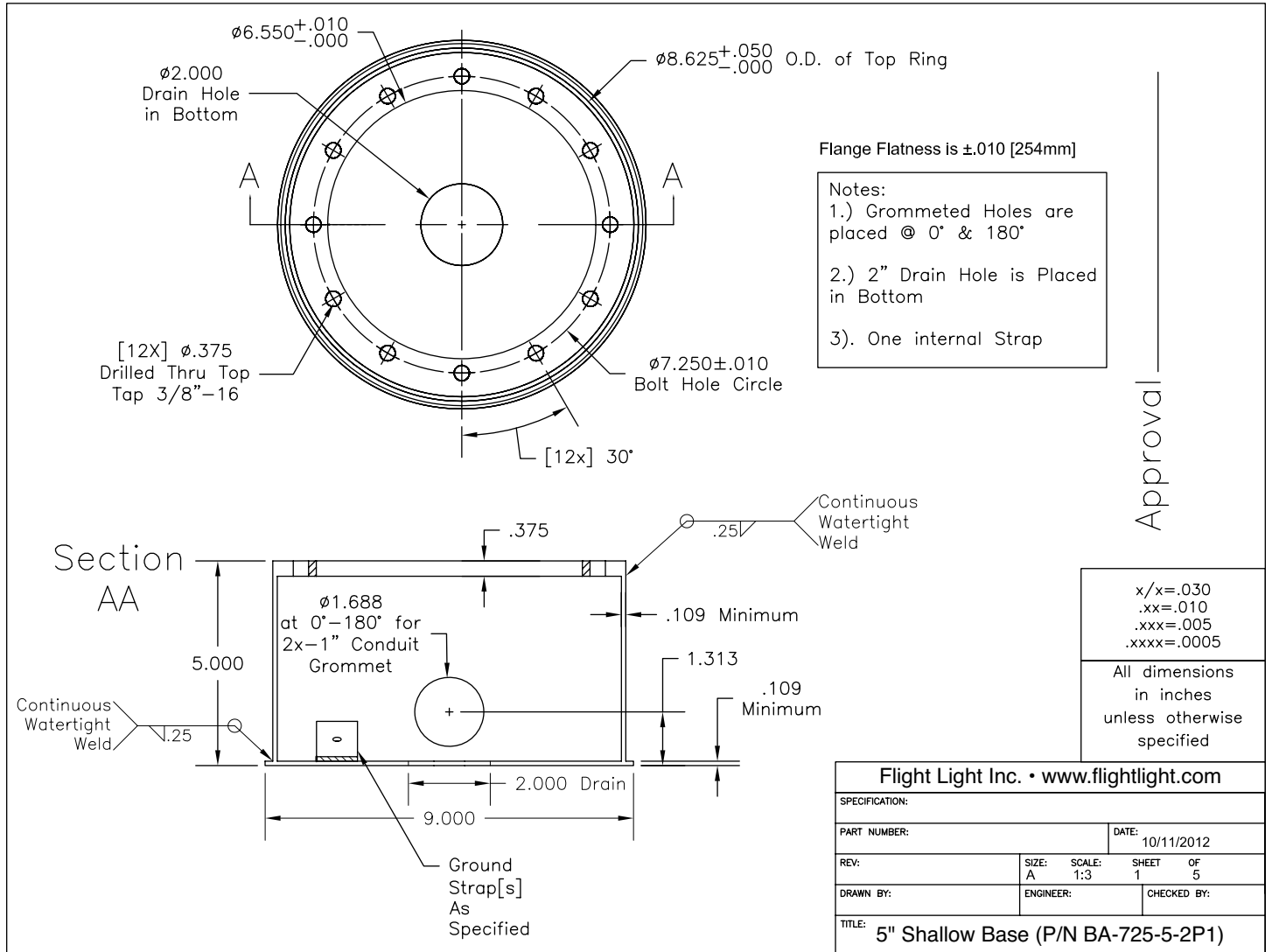

Visit our web site: www.flightlight.com



Flight Light Inc.
2708 47th Ave.
Sacramento, California, U.S.A.
95822-3806



Flight Light Inc.
Heliport Perimeter Light
FAA Compliant L-860

+1.800.806.3548
+1.916.394.2800

www.flightlight.com
sales@flightlight.com

Base Plate for L868AA 5" Shallow Base BA-1935AA-25

Specifications

- Dimensions: 8.5" diameter x .25" thick
- Bolt Circle: 7.25"
- Material: Hot rolled steel
- Finish: Aviation yellow powder coat
- Includes (6) 3/8-16 x 1" stainless steel hex head cap screws
- Part #: BA-1935AA-25

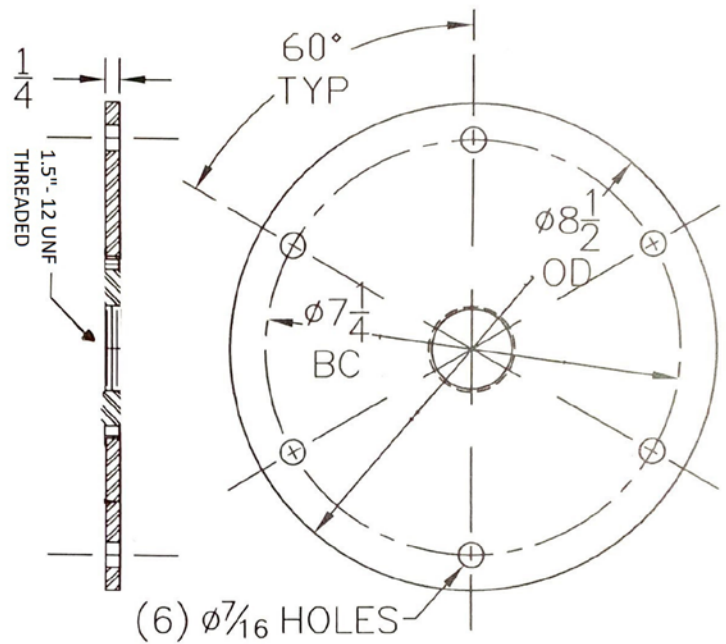

Visit our web site: www.flightlight.com



Flight Light Inc.
2708 47th Ave.
Sacramento, California, U.S.A.
95822-3806



Flight Light Inc.
Heliport Perimeter Light
FAA Compliant L-860

+1.800.806.3548
+1.916.394.2800

www.flightlight.com
sales@flightlight.com

Low Surface Mount

Rain and snow won't hurt these corrosion-resistant boxes. They feature a powder coating and are UL listed and CSA certified.

The boxes are aluminum and have NPSM (National Pipe Straight Mechanical) threaded hubs in the back and sides for secure connection to conduit and fittings. They come with closure plugs for unused hubs, a grounding screw, and attachable mounting lugs. The boxes may be mounted horizontally and vertically.

Single-device (1 gang) boxes hold one toggle switch, GFCI, duplex receptacle, or other electrical device; two-device (2 gang) boxes hold two.

Specifications:

- Number of Hubs: 5
- Hub Trade Size*: 1/2"
- Overall Size: Diameter 4-5/16", Height 2-1/4"
- Capacity: 16.5 cu. in.
- Finish: powder coating, gray

* Note: Trade size refers to an industry designation for conduit and fittings and is not an actual measurement. When selecting a box, match the trade size of the conduit.



Visit our web site: www.flightlight.com