



Flight Light Inc.
2708 47th Ave.
Sacramento, California, U.S.A.
95822-3806

+1.800.806.3548
+1.916.394.2800

www.flightlight.com
sales@flightlight.com

Base Can and Fixture Installation Instructions

Purpose:

The purpose of this procedure is to provide installers with instructions on how to install the base cans.

Procedure:

1. Base cans are shipped with protective plywood covers. Remove the base can covers and store them in a safe location.



Base Can Shown with Cover Attached



Base Can Shown with Cover Removed

2. To install base cans, begin by core drilling (typically 12" in diameter and 23" deep) holes in the locations specified by the project engineer. Saw cuts should then be made to allow room for the fixture power cables (typically 3" deep x 1/2" wide). Saw cuts are typically made in line with the centers of the conduit holes.
3. Prepare the drainage system specified by the design engineer.
4. Install the base can drain fittings provided (pictured below) into each base can drain hole. Run 1-1/2" size pipe, schedule 40 PVC, into the fittings of the base can. Pipe length should be cut so the pipe, when positioned over the drain, extends approximately 3" to 4" into the drain rock.

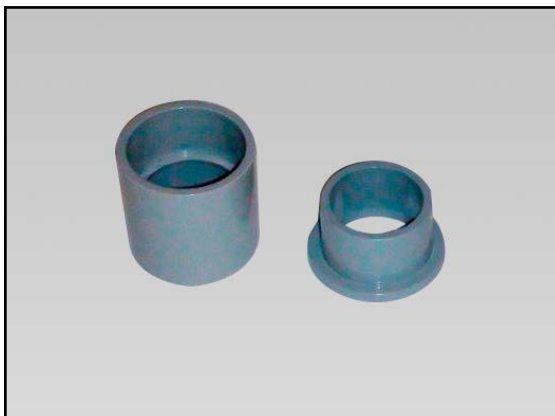

External Fitting (Left), Internal Fitting (Right)



Base Can Shown with Fittings Installed

Visit our web site: www.flightlight.com



Flight Light Inc.
2708 47th Ave.
Sacramento, California, U.S.A.
95822-3806

+1.800.806.3548
+1.916.394.2800

www.flightlight.com
sales@flightlight.com

Base Can and Fixture Installation Instructions

5. Use of a mounting jig is recommended for proper alignment of base cans. First, place the plywood cover on the base can, and then mount the mounting jig to the base can with the two bolts that fit into the base can bolt holes.



Mounting Jig Attached to Base Can



Base Can Attached to Drain Conduit



Installed Base Can

6. After the mounting jig is attached, suspend the base can so the top of the plywood cover is flush with the surface of the pavement. **Note:** When the fixture is installed (see below), the top of the fixture will mount flush with the surface of the pavement.
7. After the base cans are installed, test the drainage system by pouring water into the installed base can at each fixture location. Pour enough water to verify that the underlying ground is absorbing the water. If the base can is not draining properly, modifications to the drainage system will be necessary. In this case, consult with your project engineer before proceeding.
8. Once satisfied with drainage system, move on to the installation of the fixture power cables.
9. After all cabling has been completed, encase the base cans and drainage system in concrete. It is recommended that at least 6" of concrete be used below the base. Fill saw cuts with Traffic Loop Sealant, or equivalent. Remove mounting jig, clean out base can and replace protective plywood covers until fixtures are ready for installation.
10. Make a parallel circuit with 3M or similar waterproof splice kits. At each base can, using a fixture connector, connect the black pigtail lead to the black power wire and connect the white pigtail to the white (red) power wire. Check the integrity of the splices. At each base can, plug a fixture into the connector. Then bolt the fixture to the base can using the steel bolts provided.

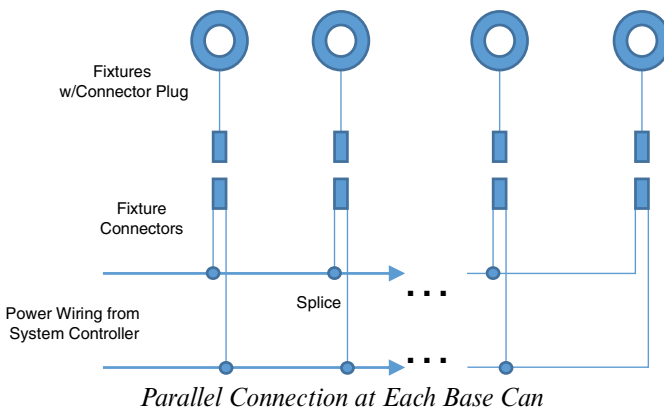

Fixture and Connector

Visit our web site: www.flightlight.com